

DESIGN AND DEVELOPMENT OF REAL TIME MONITORING SINGLE AXIS SOLAR TRACKER BY USING INTERNET OF THINGS

*Ali Basrah Pulungan, Risfendra, Wawan Purwanto, Hasan Maksum and Oktrizal Setiawan

Engineering Department, Universitas Negeri Padang, West Sumatera, Padang, Indonesia

*Corresponding Author, Received: 04 Oct. 2019, Revised: 13 Nov. 2019, Accepted: 28 Jan. 2020

ABSTRACT: The purpose of this study is to describe the design, manufacture and testing of single axis online solar tracker monitoring system with internet of things (IoT). The monitoring model consists of a series of sensors with an Arduino control system and an online display of monitoring results displayed on thingspeak. The solar panel are used in this study with a capacity of 30 WP. The testing process was carried out on the 5th floor of the Department of Electrical Engineering, Universitas Negeri Padang. Data retrieval of monitoring results takes place in real time and displayed in the form of graphic data, data information comes from sensors connected to a microcontroller then connected to a WIFI module. Futhermore the data is sent to a thingspeak server that can be accessed using notebook or android. Solar panels generate electricity from 7:00 am. to 18:00 pm for sunny weather, but for rainy weather the electric power decreases and disconnects earlier before sunset. Test results show all data can be sent properly and can be directly monitored online. Thus, the solar tracker is monitored effectively and efficiently where all data can be easily accessed with Android.

Keywords: Design, Internet of things, Monitoring system, Real time, Single axis solat tracker

1. INTRODUCTION

Indonesia is one of the countries that is crossed by the equator and has a tropical climate, so that the potential of solar energy in Indonesia is higher [1]. By using of sunlight as an energy source is possible to generate of electrical energy, especially in the equatorial region [2, 10-13], with an area of 2 million km², endowed with solar irradiation for more than 6 hours a day or about 2,400 hours a year. Solar energy on Indonesia has an intensity between 0.6 - 0.7 kW/m². The sun is the main energy source that emits enormous energy to the earth's surface. In sunny weather conditions, the surface of the earth receives about 1000 watts of solar energy per square meter, so it can be said that the source of all energy is solar energy [3].

The crucial topics to prevent of the energy crisis is solar energy. Conventional product energy are limited, high cost, and unfriendly environmental. Solar trackers are one of verious attantion for renewable energy resources [14,15]. This is interesting study, because of solar tracker can be applied in the residential homes as heating and water pumping [4]. Furthermore, with harvesting energy concept from the sun with minimal maintainability, solar tracker can be used for longer time [5, 7]. On the other hand, solar tracker is one of the future power generation technologies that is environmentally friendly and a savings solution to high electricity tariffs. In its operation, we need a monitoring system that can monitor the activities of

converting solar energy into electrical energy to increase the reliability and security of the system. To see the performance produced by the Solar tracker a reliable and accurate monitoring system is needed [5].

Several solar tracker monitoring techniques have been developed in previous studies. The GSM-based solar electricity monitoring and control technique was developed by Gagliarducci [6]. This GSM-based monitoring technique has proven to be inexpensive and tested for its effectiveness [8]. Another technique that is, tracker 3 position solar panels increases energy conversion with low power supply [2,16]. Furthermore, monitoring techniques using wireless sensor networks and the use of cloud storage systems to handle large data have been carried out [7]. However, the design of the display results of monitoring using thingspeak has not been much discussed. In addition, analysis methods have been developed related to arduino Uno controller [6], algorithm [4] system development, design and development [9], and analysis for actuators [5]. Furthermore, in this study an online monitoring system was designed using an arduino uno sensor circuit. The use of this programming language will make it easier to monitor directly from time to time for incoming information. Data processing and activities that occur can be monitored online through the thingspeak server. Solar tracker real time monitoring system will help users in monitoring the condition of the electric power [8].

In addition, the monitoring system makes it easy

to evaluate the efficiency of solar panel power output, algorithm models, electromechanical structure models have been developed. To test the success of the developed model, an experimental application of solar tracker monitoring is applied in the prototype of the solar tracker.

2. BASIC THEORY

2.1 Fundamental Theory of Solar Tracker Monitoring

By applying the solar panel, the solar energy are possible to convert to be electrical energy. The converting process are starting from the sun and a thermal collector to the heat. Then, solar energy produced are proportional with the intensity of irradiance filling on the photovoltaic (PV) surface. The solar heat that reached the earth is extraterrestrial irradiance, and the intensity of the solar heat are different based a day of year because of meteorological situation. In the horizontal surface condition the extraterrestrial irradiance can be calculated as [8]:

$$I_{ah} = I_{sc} \left(1 + 0.0333 \cos \frac{2\pi}{365} n \right) \cos \theta_z \quad (1)$$

Where I_{ah} is the extraterrestrial radiation, I_{sc} is the solar heat constant, n is the day of a year, θ_z is the angle between sunbeam to the normal surface of the earth (zenith angle). Then, by developing meinel model the global horizontal irradiance (GHI) model can calculated as (2), direct normal irradiance (DNI) model (3), diffuse horizontal irradiance (DHI) model (4), and air mass of the sun's rays traveling by the earth atmosphere (5).

$$GHI = DNI \cos(\theta_z) + DHI \quad (2)$$

$$DHI = 14.29 + 21.024 \left(\frac{2\pi}{2 \frac{\theta_z \pi}{180}} \right) \quad (3)$$

$$DNI = I_{ah} 0.7^{AM^{0.678}} \quad (4)$$

$$AM = \frac{1}{\cos(\theta_z)}, \text{ for angle } \leq 70^\circ \quad (5)$$

To receive the monitoring system in this study, microcontroller are designed for reading the azimuth angle from the sun's position, than a movement of the motor for the solar panel in the sun's ray position at the present time (elevation angle) [6]. In this study, a way to get higher solar radiation is applied by adjusting the position of the solar module, where the position of the solar module can be adjusted to follow the movement of the sun's direction by determining the position of the tilt angle, the azimuth surface angle as shown in Fig 1.

2.2 Electromechanical Structure Model

The electromechanical design of the solar tracker monitoring in this study as explained in Fig 2 and the prototype design in Fig 3. It is described that the monitoring system starts with the sun's light absorbed by the solar panel as a battery, it is used as the main power in the design. Then, the solar panel is driven by a DC motor controlled by ATmega 2560. The solar panel continues to move 5 positions in the direction of the falling light the sun is based on the time based on Indonesia of meteorological and geophysical agency (BMKG) data on the sun's azimuth angle, time of sunrise, and sunset then the data is sent by ESP 8266 module to be monitored in realtime through the thingview application.

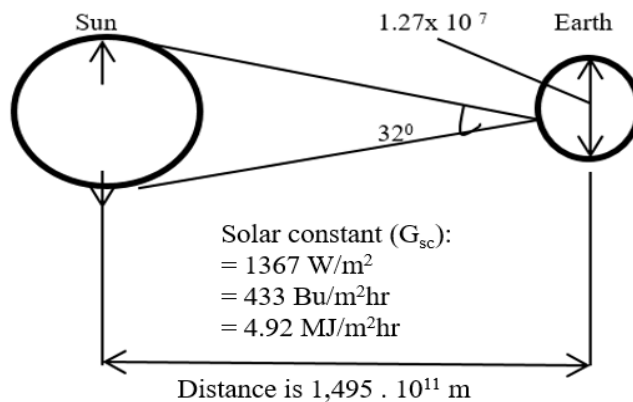

Fig. 1 Topography of sun and earth

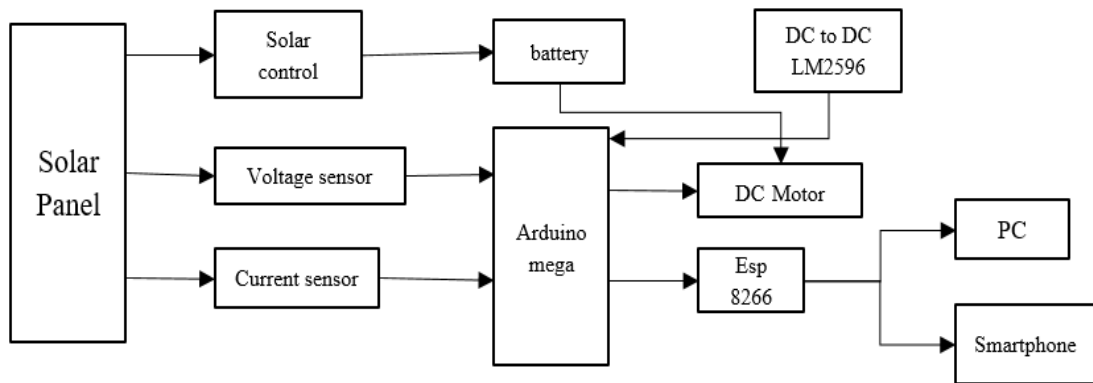

Fig. 2 Monitoring system flowchart



Fig. 3 Prototype of solar tracker

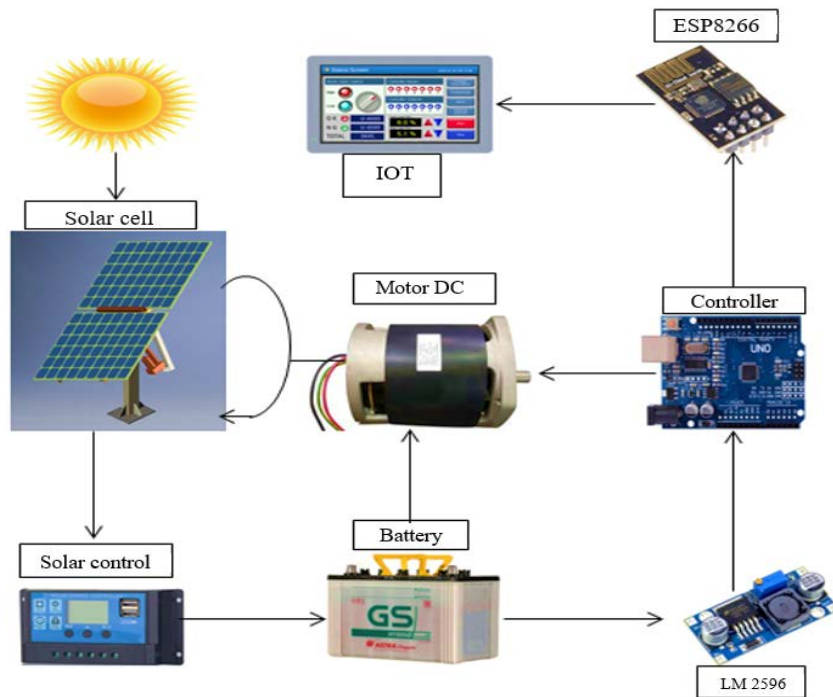

Fig. 4 Implementation of monitoring solar tracker flowchart

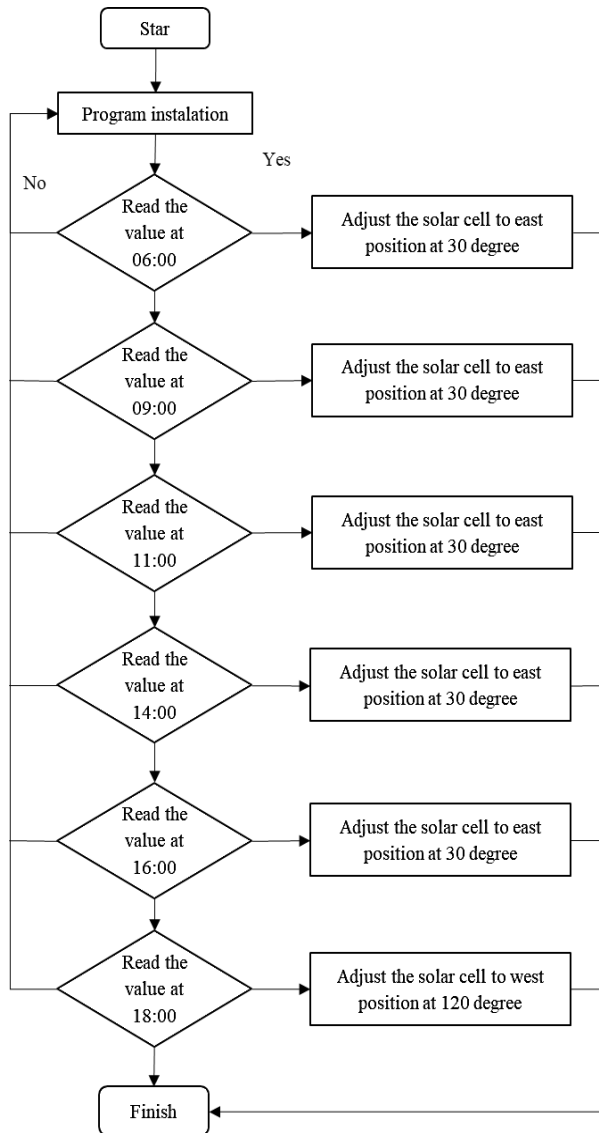

Fig. 5 Flowchat implementation procedures

3. IMPLEMENTATION PROCEDURES

In the design of ATmega 2560 based solar tracker monitoring system, the microcontroller is the main controller in this system, all sensor data is sent to the microcontroller which is sent to the Esp8266 using wifi module. Then, the data sent to the thingspeak server. Thingspeak is an IoT analysis platform service that allows to collect, visualize, and analyze data that flow directly in the cloud. Data is sent to thingspeak from a developed device makes an instant visualization of data directly, and sends alerts. The implementation process as shown in Fig 4. Monitoring data is taken at an hour in the range of 2 to 3 hours according to sun heat conditions. The Implementation procedure as shown in Fig 5. For the prototype implementation in this study, motor power window are applied. The motor convert the electrical energy to be

mechanical energy in the PV movement. In the control motor we use driver circuit with ATmega 2560 as a main control.

Table 1. Voltage and current data

No	Time	Position 1		
		V	A	P (W)
1	06.18	12,5	0,21	2,6
2	06.48	12,53	0,28	3,5
3	07.18	13,21	0,45	5,9
4	07.48	14,18	0,5	7,1
5	08.18	15,49	0,84	13

No	Time	Position 2		
		V	A	P (W)
1	09.18	16,47	1,02	16,8
2	09.48	16,2	1,17	18,9
3	10.18	17,31	1,5	25,9
4	10.48	16,45	1,63	26,8
5	11.18	16,54	1,66	27,4

No	Time	Position 3		
		V	A	P (W)
1	11.48	18,14	1,75	29,8
2	12.18	18,43	1,75	29,9
3	12.48	18,43	1,74	29,9
4	13.18	18,12	1,66	29,12
5	13.48	18,14	1,68	30,24

No	Time	Position 4		
		V	A	P (W)
1	14.18	18,48	1,68	30,2
2	14.48	17,58	1,58	27,7
3	15.18	17,43	1,54	26,8
4	15.48	17,11	1,54	26,3
5	16.18	17,12	1,45	24,8

No	Time	Position 5		
		(V)	(A)	P (W)
1	16.48	16,48	1,15	18,9
2	17.18	16,15	1,02	16,4
3	17.48	15,48	0,87	13,4
4	18.18	14,45	0,87	12,5
5	18.28	14,07	0,77	10,8

4. RESULTS AND DISCUSSION

The data collection process was carried out on the 5th Floor of the Department of Electrical Engineering, Universitas Negeri Padang. This solar tracker monitoring system uses monocrystalline

solar panels with a capacity of 30 WP. Data is collected from 06.18 - 18.28. The data generated in the form of V (Voltage) and I (Current), which is directly monitored the performance of the electrical energy produced by the solar tracker. All the data that is monitored can be saved. In the process of collecting weather data tends to change around the campus. The results of monitoring of implementation are as shown in Table 1.

As explained in Table 1, the position first of the solar cells power generated continues increase along with the intensity of sunlight hitting the solar panel. In position second, the power generated also continues to rise because the position of the solar panel has moved to follow the angle of the sun guided by the clock from Indonesia of meteorological and geophysical agency data. In the third position the sun's intensity begins to change, when the sun blazes the power generated continues to rise. The solar panel continues to face the sun's angle, in the third position the sun's angle is at an angle of 90° or at 11: 48 - 13: 48. In the fourth position the power produced begins to fall, the intensity of the sun begins to dim, at this position the solar panel exposes to an angle of 120° . In the fifth position the power generated continues to fall, because the sun begins to set, the angle of the sun at position five is at an angle of 16° . The power generated at the implementation as shown in Fig 6.

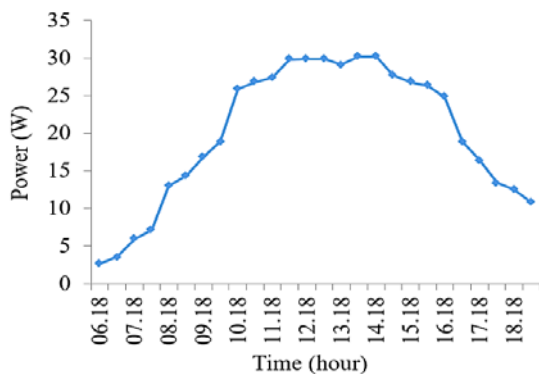

Fig. 6 The distribution of solar cell power

The tracker solar panel continues to move five positions guided by the angle of the sun based on BMKG data, the power generated continues to increase along with the high intensity of sunlight shining on the solar panel, with the tracker solar panel moving as many as five positions is very effective to increase the output power of the solar panel. The voltage sensor works with the principle of a voltage divider the input voltage can be reduced 11 times the input voltage using resistors R_1 (100kOhm) Ohm and R_2 (10 kOhm). So the output of the sensor will be maximum of +5 VDC because the maximum voltage that can be converted by the ADC is +5 VDC. The experimental carried out by

measuring the voltage of the output solar panel and comparing to the measurement results with voltmeter. To compare the data from the sensor and voltmeter, it is using several times in order to calculate the error from the sensor. From the implementation and tabulation data. The biggest error is 0.8%. This appear because of component factors, environmental conditions, and the algorithm. According to researchers the error obtained is in the reasonable limit so the voltage sensor can work be a reference sensor value. The monitoring view of voltage as long as implementation is shown in Fig 7.

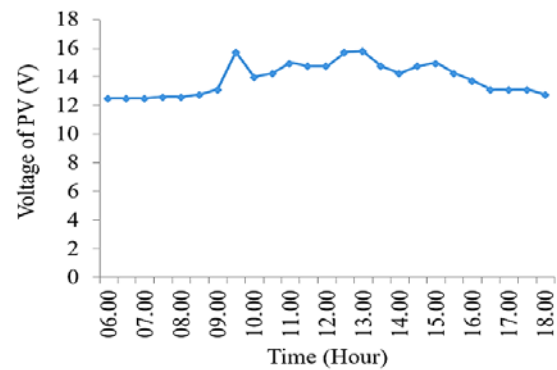

Fig. 7 Voltage monitoring view

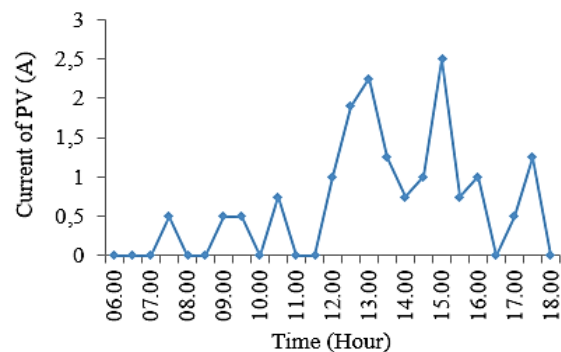

Fig. 8 Current monitoring view

The results of current observations obtained from the ACS712 current sensor. It emits a voltage of 2.5 V with no input current. Whereas if there is a current flowing from the microcontroller, the voltage will be higher than 2.5 V. Otherwise, if the current flows from the microcontroller the voltage is higher than 2.5 V. Application the current sensor can be taking current data from the solar panel and comparing with ohmmeter data. Experimental measurement carried out ten times, so that the error of the current sensor can be achieved. From the data, the largest ACS712 current sensor error is 1.8%. This is caused by these sensor factors, as well as the environment where the data is retrieved and the algorithm of the sensor program. According to previous researchers results, the error is within reasonable limits. The documentation of

the current as shown in Fig 8.

To determine the accuracy of the real time clock (RTC) module on the hours, days, and dates according to the situation, the validation test is performed. Testing is performed by comparing the results of the RTC with the time on the cell phone which is set automatically using the internet instead of manual settings. So its accuracy is quite guaranteed. Table 2 is the comparison of the results of the DS3231 RTC module displayed in the arduino serial monitor, the time on the netbook and the time on a smartphone that has an automatic update feature in accordance with the local time, the results are shown in Table 2. From the table shows that an error can be seen from the sensor is 0.

Testing esp8266 module to determine the accuracy in sending sensor data to the server thingview. Testing is done by comparing the results of sensor output with those sent to the server, the results are shown in Table 3.

Table 2. RTC measurement

No	Voltmeter (V)	Real measurement (V)	Error (%)
1	5	5	0%

Table 3. Esp8266 module monitoring results

No	Voltage of PV (V)	Voltage in thingspeak (V)	Current of PV (A)	Curent in thingspeak (A)
1	12,56	12,50	0,51	0,50
2	12,60	12,53	0,51	0,50
3	12,61	12,54	0,77	0,75
4	12,65	12,61	1,02	1,00
5	12,68	12,61	1,92	1,90
6	12,80	12,77	2,27	2,25
7	13,21	13,13	2,52	2,50
8	15,90	15,76	0,51	0,50

5. CONCLUSION

Based on the implementation results and analysis of the ATmega2560 one axis solar tracker monitoring system, it can be concluded that the design of hardware and software for the controller one-axis solar tracker monitoring system performed of the real data monitoring. The voltage, current and power data are successfully monitored in real time through thingview. The solar panel tracker has been successfully tested, using five positions. Tests and analyzes have been carried out, both tracker analysis and monitoring obtained by measuring data which is actually the error data monitored less than 5%.

REFERENCES

- [1] Satya W.Y, and Benny T., Stakeholder Mapping and Analysis of the Renewable Energy Industry in Indonesia, *Enegies*, Vol. 12, No. 602, pp. 2-19, 2019.
- [2] Welly Y, Syafii, and Pulungan A.B., Three axis solar tracker monitoring for improving energy conversion with low current supply, post graduate thesis in Universitas Andalas, Padang, pp. 1-178, 2017
- [3] Saiful M., The efficient of solar energy, reliable, and environmental friendly of alternative energy source in Indonesia, post graduate thesis in Universitas Diponegoro, Indonesia, pp. 1-89, 2009
- [4] Vukica M. Jovanovic, Michael S, Orlando A, and Sylvain M., Single Axis Solar Tracker Actuator Location Analysis, *IEEE international Symposium on Industrial Electronics*, March 30–April 03, pp. 1-5, 2016, Norfolk, VA, USA.
- [5] Subhasri G, and Jeyalakshmi. C., A Study of IoT based Solar Panel Tracking System, *Advances in Computational Sciences and Technology*, Vol.11, No. 7, pp. 537-545, 2018
- [6] Wafa B, Ahmad B, Ibrahim S, and Saleh A.H., Investigation of a single-axis discrete solar tracking system for reduced actuations and maximum energy collection, *Automation in Construction*, Vol. 98, No. 2, pp. 102-109, 2019
- [7] Jose A.C, Javier B, Lidia R, and Manuel B., New low-cost solar tracking system based on open source hardware for educational purposes, *Solar Energy*, Vol.174, No. 3, pp. 826 – 836, 2018
- [8] Emmanuel K.M, Zeundjua T, and Oduetse M., Review of dual axis solar tracking and development of its functional model”, *Procedia Manufacturing*, Vol. 35, No.2, pp. 580–588, 2019
- [9] Marco R.C, Paola, R.C, Giuseppe M.T, and Cristina V., RAST: Round About Solar Tracking, 9th International Conference on Sustainability in Energy and Buildings, SEB-17, 5-7 July 2017, Chania, Crete, Greece. *Energy Procedia*, Vol. 134, pp. 598–606, 2017.
- [10] Grachev V.A., Environmental Effectiveness of Energy Technologies, *International Journal of GEOMATE*, Vol.16, Issue 55, pp. 228 – 237, 2019
- [11] Ariya A, Yoshihito K, Kenta F, and Jin I, “The Integration of Human Thermal Comfort in an Outdoor Campus Landscape in a Tropical Climate”, *International Journal of GEOMATE*, Vol.14, Issue 44, pp.26-32, 2018
- [12] Maria M, John R, Daniela I, and Bandita M., Sea Levels in a Changing Climate, *International Journal of GEOMATE*, Vol.14, Issue 43, pp.24-30, 2018

- [13] Maksum H, Purwanto W, and Wanda A., Design of Electromagnetic Regenerative Shock Absorber as a Tool of Harvesting Vibration Energy on Vehicle, *International Journal of GEOMATE*, Vol.15, Issue 50, pp. 1 – 7, 2018
- [14] Purwanto W, Sugiarto T, Maksum H, Martias, Nasir M, Agus B., Optimal Design of Rotor Slot Geometry to Reduce Rotor Leakage Reactance and Increase Starting Performance for High-Speed Spindle Motors, *Advances in Electrical and Electronic Engineering*, Vol. 17, No. 2, pp. 96-105, 2019
- [15] Purwanto W, Maksum H, Sugiarto T, Nasir M, Martias, Rizal F., The Effect of Stator Winding Parameter Design to the Magnetic Flux Characteristics in High-speed Motor Applications, Vol. 97, No. 12, pp. 3270-3280, 2019
- [16] Purwanto W, Hasan M, Dwi S.P, Mery A, and Retno W., A study experimental of Auto idle Application in the excavator engine performance. *AIP Conference Proceedings*, vol. 1717. No. 1. 10.1063, pp. 1 – 5, 2016

Copyright © Int. J. of GEOMATE. All rights reserved, including the making of copies unless permission is obtained from the copyright proprietors.
