

DEVELOPMENT OF ACOUSTICAL SIMULATION MODEL FOR MUFFLER

Wei-Hong Tan¹, T.S. Khor², N.H. Zunaidi³

^{1,2,3}Mechanical Engineering Programme, School of Mechatronic Engineering, Universiti Malaysia Perlis (UniMAP), Pauh Putra Campus, 02600 Arau, Perlis, Malaysia.

ABSTRACT: Mufflers have been widely used to reduce the noise level emitted from various vehicles. The simple and high accuracy simulation model for muffler is highly requested by designers in evaluation stage of preliminary design. In this paper, the simulation model was developed by using SysNoise application in LMS Virtual Lab. The basic geometry of simple expansion chamber muffler was proposed for simulation and evaluation in terms of transmission loss (TL). The developed model via simulation had been verified by comparing the predicted TL of simple expansion chamber muffler with the experimental data in literature. It can be observed that simulation results have good agreement with the experimental data from literature. In addition, simulation-based muffler analysis also was conducted for parametrical studies in order to enhance the TL of muffler. As a conclusion, the computational acoustic model based on Finite Element Method (FEM) was successfully developed for prediction of TL on mufflers.

Keywords: Muffler, Transmission Loss (TL), Acoustical Simulation, Finite Element Method (FEM)

1. INTRODUCTION

Muffler is one of the components used to reduce the noise from a system containing a noise source connecting to a tube. For example, combustion engines, compressors, and air-conditioning system. For modern vehicles, generally it is installed in the tail section of the exhaust pipe part, to suppress the noise generated by engine exhaust emissions in reducing the exhaust and intake system noise. A lot of researches were done on designing these muffling systems. The traditional “build & test” procedure is considered time consuming and expensive, and it can be assisted by acoustical simulation models at the preliminary stage. By this, the initial performance of the designed muffling system can be predicted. In general, muffler can be defined by two types, which are reactive and dissipative [1].

Reactive muffler is composed by several chambers with different volumes and shapes connected together with tubes, and it can reflect the sound energy back to the source, they are virtually sound filters and very useful for the noise either there is a hot, dirty or high-speed gas flow. Reactive muffler also can be made inexpensively and maintenance free. However, dissipative muffler uses acoustic absorbing material to absorb the acoustic energy and turn it into heat. These type mufflers suitable for the source produces noise in a broad frequency band and effective for high frequencies [2,3]. Selection this type muffler will depend upon the noise source and environmental factors.

Transmission loss (TL) of muffler is considered an important parameter for the designing works. In the past few decades, a lot of research works have been conducted to present this work. Normally, the TL of muffler obtained by using two-load method, three-point method [4], and four-pole method [5]. TL is considered the discrepancy in the sound power between the incident wave entering and the transmitted wave exiting the muffler when the muffler termination is anechoic [6].

In this study, acoustic performance of the muffler is simulated and analyzed. Normally, a muffler or a silencer is used to reduce the noise emitted by the exhaust due to the internal combustion engine. By having the acoustical simulation modeling of the muffler, it will help to identify the TL of muffler in the early stage of design. The acoustical simulation result of the muffler will allow manufacturers to understand the function and the traits of a muffler before manufacturing it.

2. THEORETICAL DEVELOPMENT

2.1 Two-load Method

Two-load method is one of the popular approaches to be used for calculating the transmission loss (TL) of muffler. For the two-load method [7], when the loads are very similar, the TL result will become unstable. Normally, two loads situation can be achieved by two different length tubes or a single tube with and without absorbing material as shown in Fig. 1.

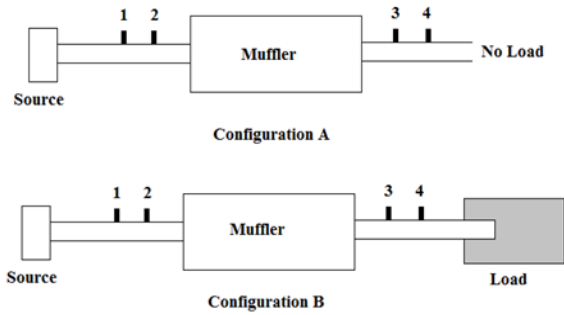

Fig. 1 Two-load method [6,8]

The two load method is based on the transfer matrix approach [8]. This method is used four-pole equation to obtain the TL of muffler, so the formulae almost similar with four-pole method and it easier to be used compare with four-pole method.

$$\begin{bmatrix} p_1 \\ v_1 \end{bmatrix} = \begin{bmatrix} A & B \\ C & D \end{bmatrix} \begin{bmatrix} p_2 \\ v_2 \end{bmatrix} \quad (1)$$

Where: p_1 = sound pressure at the inlet, p_2 = sound pressure at the outlet, v_1 = particle velocities at the inlet, v_2 = particle velocities at the outlet.

$$A=(p_1/p_2) | v_2=0, v_1=1 \quad (2)$$

$$B=(p_1/v_2) | p_2=0, v_1=1 \quad (3)$$

$$C=(v_1/p_2) | v_2=0, v_1=1 \quad (4)$$

$$D=(v_1/v_2) | p_2=0, v_1=1 \quad (5)$$

Finally, the transmission loss can be obtained as the formula below [9],

$$TL = 20 \left(\frac{1}{2} \left| A + \frac{B}{\rho c} + C \rho c + D \right| \right) \quad (6)$$

ρ = air density, c = speed of sound

For a simple expansion chamber muffler, the theoretical TL can be calculated by Eq. 7 [10, 11] using the 1-dimensional plane-wave approach,

$$TL = 10 \log_{10} \left[1 + \frac{1}{4} \left(m - \frac{1}{m} \right)^2 \sin^2 kl \right] \quad (7)$$

where $m = \frac{S_c}{S_i}$, S_c is the area of cross-section central chamber, and S_i is the area of cross-section inlet pipe, k is wave number and l is the length of central chamber.

3. METHODOLOGY

3.1 LMS Virtual.Lab Acoustic

In this study, the software of LMS Virtual.Lab Acoustic will be used to build the FEM model of muffler, acoustical simulation, and the calculation of muffler TL. The software is considered user friendly as the simulation model easy to be built or designed.

By using this software, the acoustical simulation model of muffler was developed and the performance of muffler can be analyzed before carrying out the prototyping.

3.2 Acoustical Simulation Procedures

In LMS Virtual.Lab software, the CAD model of muffler is drawn and meshed. Then the meshed muffler model is imported into the acoustic harmonic FEM module of the software for simulation. For the acoustical simulation, the acoustic properties were defined. In this simulation, 340m/s is speed of sound and 1.225kg/m³ for mass density.

There are two boundary conditions are applied on the model. The boundary conditions are imposed at the inlet and outlet. The normal velocity with the harmonic amplitude 1 m/s is applied to the inlet, and acoustic impedance, $\rho c=416.5 \text{ kg/m}^2\text{s}$ is defined to the outlet for creating the anechoic termination. In order to determine the TL of simulated muffler, input and output point (I/O point) are defined at the inlet and outlet.

4. RESULT AND DISCUSSION

There are five muffler configurations were analyzed using the acoustical simulation method. The configurations include simple expansion chamber muffler, double expansion chamber muffler, simple elliptic expansion chamber, simple elliptic expansion chamber with extended tube at the inlet or outlet muffler, and expansion chamber with perforated tube muffler. The acoustical simulation results and discussions were presented in the following section.

4.1 Simple Expansion Chamber Muffler

Figure 2 shows the geometry of the modeled muffler and isometric view for the simulation analysis.

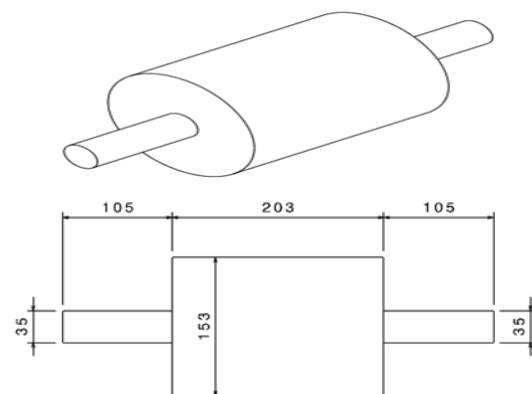

Fig. 2 All dimensions in millimeter (mm) and isometric view

Figure 3 shows finite element method (FEM) result compared with analytical result and experimental measurement of Z. Tao et al., 2003 [6]. 50-3000 Hz frequency range was chose in the simulation. In the comparison, it is apparent that the analytical result deviates from the experimental measurement and FEM result for the frequency range 500-3000 Hz. On the other hand, FEM results show good agreement with experimental result for the frequency range 0-2500 Hz. Frequency 2500 Hz and above, the result deviates from each other, it is most probably caused by insufficient anechoic termination [6]. Based on the observation in Fig. 3, the FEM is considered more accurate than analytical method compared with experimental measurement of Z. Tao et al., 2003 [6] as the correlation coefficient is 0.94.

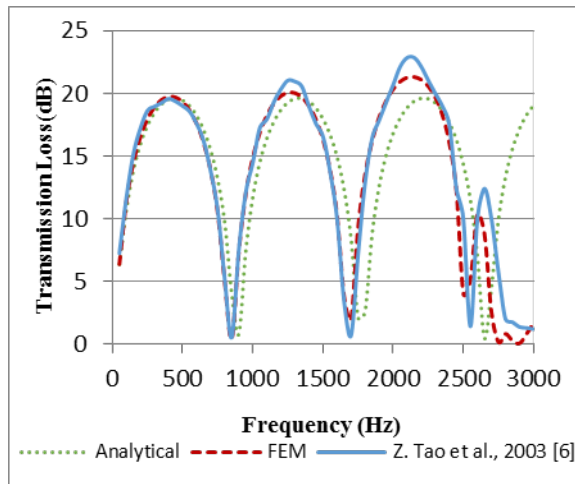

Fig. 3 Transmission loss of simple expansion muffler obtained by analytical, FEM and experimental measurement of Z. Tao et al., 2003 [6]

4.2 Double Expansion Chamber Muffler

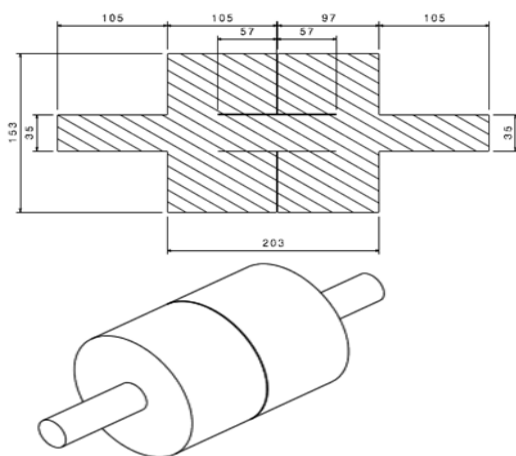

Fig. 4 All dimension in millimeter (mm) and isometric view

The dimension and isometric view of double expansion chamber muffler for the acoustical simulation analysis are shown in Fig. 4.

Figure 5 shows FEM result compared with BEM and experimental measurement result obtained in the study of Z. Tao et al., 2003 [6]. Based on Fig. 5, FEM analysis shows the similar TL trend with the experimental measurement for the frequency range 50-950 Hz. Frequency range 950-1200 Hz and 1800-2150 Hz, the TL curve of FEM and BEM deviate from each other's. Although the FEM results are different with the experimental measurements, the data still can be accepted since the correlation coefficient is 0.86.

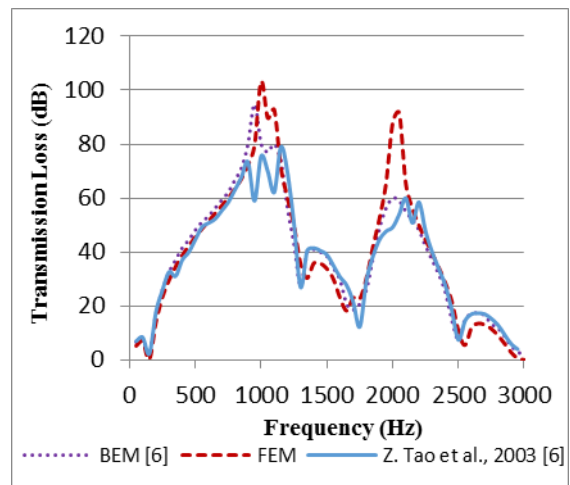

Fig. 5 Transmission loss of double expansion muffler obtained by BEM [6], FEM and Experimental measurement of Z. Tao et al., 2003 [6]

4.3 Simple Elliptic Expansion Chamber Muffler

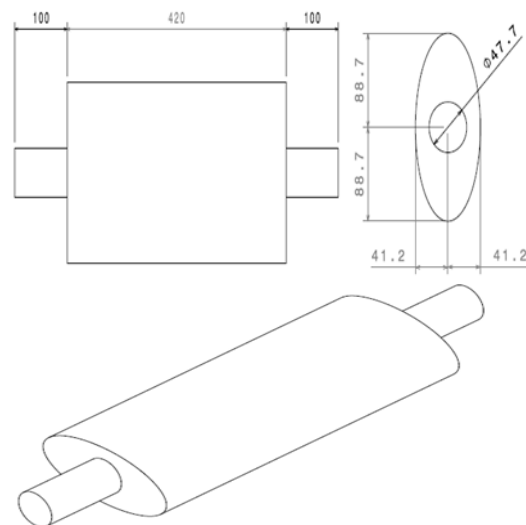

Fig. 6 Geometry of a simple elliptic expansion chamber muffler and isometric view

Figure 6 shows the geometry of a simple elliptic expansion chamber and isometric view. The dimension unit for the geometry is in millimeter (mm).

Figure 7 shows the comparison between the experimental measurements [12] and the FEM numerical TL results. There is 50-3000 Hz frequency range was selected for the simulation analysis. Based on Fig. 7, it is showed that the TL curve is good agreement with each other's for the first loop to last loop, where the maximum differences of 5 dB only. The highest peak TL for FEM drops at 2400 Hz with TL of 28 dB. However, the highest peak of experimental measurement drops at 2600 Hz, which the TL is 32 dB. The correction coefficient between FEM results and experimental measurement for the frequency range 50-2000 Hz is 0.68.

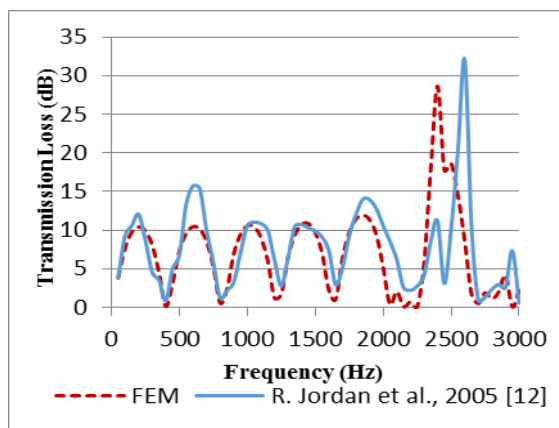

Fig. 7 Transmission loss of simple elliptic expansion chamber obtained by FEM and experimental measurement of R. Jordan et al., 2005 [12]

4.4 Simple Elliptic Expansion Chamber with Extended Tube

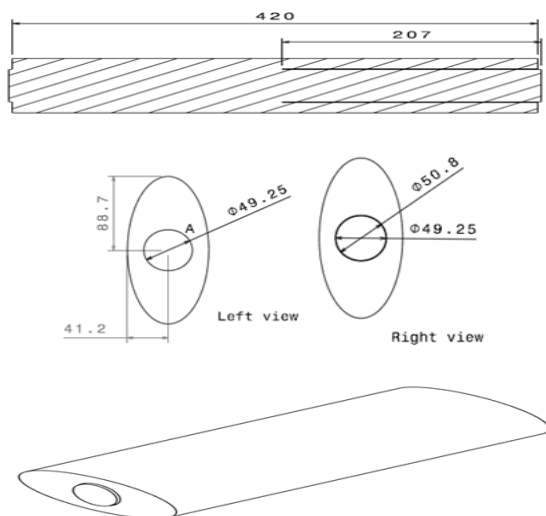

Fig. 8 Muffler attached with the extended tube at the inlet and isometric view

Figure 8 is another type of simple elliptic expansion chamber muffler attached with the extended tube at the inlet. The unit for the dimension of the chamber is in millimeter (mm).

The comparisons between the values of TL obtained from experimental measurement [12] and FEM are shown in Fig. 9. There is 50-3000 Hz frequency range was selected for the simulation analysis. Based on Fig. 9, the first three peaks of the TL are very similar with each other for the frequency range 50-2000 Hz. The highest peak TL for FEM and experimental measurement drop at 1200 Hz with TL 71 dB and 40 dB respectively. The frequency 2000 Hz and above, no significant TL was observed. There is 0.76 of correlation coefficient between FEM results and experimental measurements for the frequency range 50-2000 Hz.

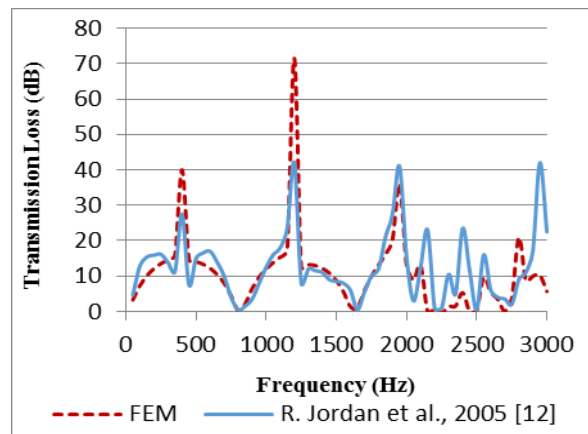

Fig. 9 Transmission loss of chambers with extended tube obtained by FEM and Experimental measurement of R. Jordan et al., 2005 [12]

4.5 Muffler with Perforated Wall

Figure 10 shows the model dimension was selected for acoustical simulation analysis and the results will be compared with the experimental result of Sullivan and Crocker [13]. The diameter perforations on the perforated wall are 0.00249m and 0.00081m for the wall thickness. The porosity of the perforated wall is 3.8%.

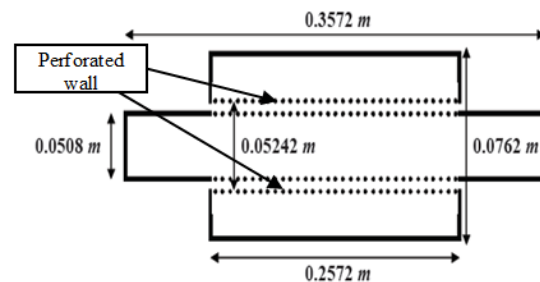

Fig. 10 Model dimension [14]

Figure 11 shows the FEM results compared with experimental results [13]. There is 10-3600 Hz frequency range was selected for this simulation. By referring to Fig. 11, the TL of muffler with perforated wall has a good agreement with Sullivan and Croker's results [13]. The relatively high correction coefficient of 0.89 in this comparison.

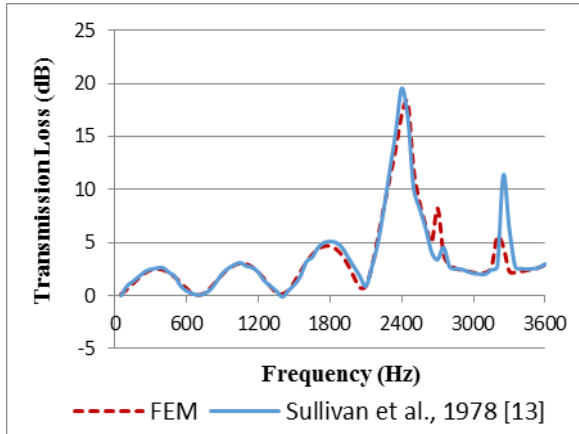

Fig. 11 FEM result compare with experimental result of Sullivan and Crocker [13]

4.6 Parametric Study on Simple Expansion Chamber Muffler

In this section, the basic design simple expansion chamber muffler was selected and used for parametric study. Fig. 12 depicts the geometrical parameters of the muffler and Table 1 lists 4 geometrical dimensions for 4 designs of muffler. The diameter, length of inlet and outlet tubes are remain constant for the parametric study. For the chamber, the length is unchanged and the diameter is changed to 75 mm, 125 mm, 175 mm and 225 mm accordingly.

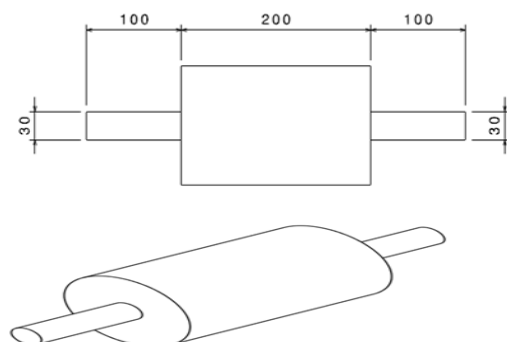

Fig. 12 Dimension and isometric view

Table 1 Length and Diameter for different design type of muffler

Design Type	1	2	3	4
Length (mm)	200	200	200	200
Diameter (mm)	75	125	175	225

Figure 13 shows the simulation result by using the built model FEM. 0-3000 Hz frequency range was chose in this simulation. Based on Fig. 13, it is observed that the bigger diameter of the chamber will produce higher TL for the frequency range 0-1750 Hz. For the frequency 1750 Hz and above, the TL curve obtained from design type 3 and design type 4 are deviating with each other. However, the TL curve of design type 1 and 2 are similar for the frequency range 0-3000Hz.

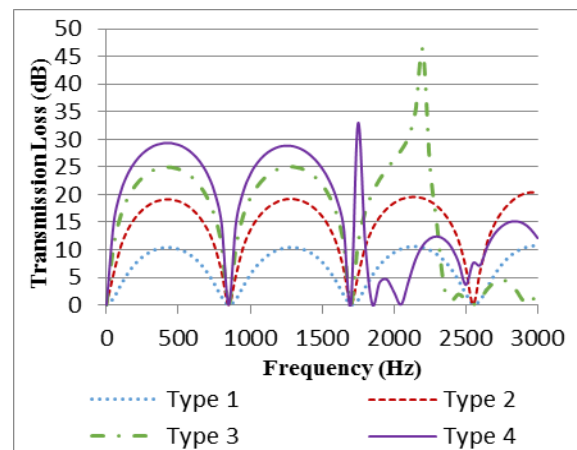

Fig. 13 Transmission loss of different design of the muffler

5. CONCLUSION

In this study, the results of FEM simulation for each of the muffler are good agreement with the experimental measurement results. Especially, the results of TL for simple expansion chamber muffler, double expansion chamber muffler and chamber with perforated tube muffler almost similar compared with the experimental measurement results, which give the correlation coefficient in between 0.76 to 0.94. This proves the FEM acoustical simulation model of muffler is developed successfully and validated, and the FEM model analysis on the muffler can be used to predict the TL of muffler in the early stage of design before prototyping.

6. ACKNOWLEDGEMENTS

This paper is done with the financial support from Universiti Malaysia Perlis (UniMAP) Incentive Grant (No Project: 9007-00252). Technical Support from USM TheVibration Lab also is greatly acknowledged.

7. REFERENCES

- [1] Kumar. S, "Linear Acoustic Modeling and Testing of Exhaust Mufflers", M.S. thesis, Royal Institute of Technology, Stockholm, Sweden, 2007.
- [2] Beraek L.L, Noise and vibration control. New York: McGraw-Hill, 1971.
- [3] F. Cui, Y. Wang, R. C. Cai, "Improving muffler performance using simulation-based design", in INTER-NOISE and NOISE-CON Congress and Conference Proceedings, 2014, pp. 1190-1194.
- [4] T.W. Wu and G. C. Wan, "Muffler Performance Studies Using a Direct Mixed-Body Boundary Element Method and a Three-Point Method for Evaluating Transmission Loss", J. of Vibration and Acoustics, Vol. 118, Jul.1996, pp. 479-484.
- [5] T.W. Wu and P. Zhang, "Boundary Element Analysis of Mufflers With an Imposed Method for Deriving the Four-Pole Parameters", J. of Sound and Vibration, Vol. 217, June. 1998, pp.767-779.
- [6] Z. Tao and A.F. Seybert, "A review of current techniques for measuring muffler transmission loss",SAE International, in Noise & Vibration Conference & Exhibition, Traverse City, 2003.
- [7] Lung, T.Y, Doige, A.G, "A Time-Averaging Transient Testing Method for Acoustic Properties of Piping Systems and Mufflers", J. of Acoustical Society of America, Vol. 73, Mach. 1983, pp. 867-876.
- [8] M.B. Jadhav and A. P. Bhattu, "Validation of the Experimental Setup for the Determination of Transmission Loss of Known Reactive Muffler Model by Using Finite Element Method", International J. of Engineering and Innovative Technology , Vol. 2, July. 2012.
- [9] S. Bilawchuk, K.R. Fyfe, "Comparison and implementation of the various numerical methods used for calculating transmission loss in silencer systems", Applied Acoustics, Vol. 64, Feb. 2003, pp. 903-916.
- [10] Bell LH, Industrial noise control. New York: Marcel Dekker, 1994.
- [11] Bhattacharya. P, Panua. R, Bose P. K, Ghosh B, "Design of Reactive Muffler for Study on the Noise Level and Performance of a Two Cylinder Four Stroke 16 H.P Diesel Engine", Noise Worldwide, Vol. 39, Sept. 2008, pp 24-27.
- [12] S. N.Y. Gerges, R. Jordan, F. A. Thieme, J. L. Bento Coelho, J. P. Arenas. "Muffler Modeling by Transfer Matrix Method and Experimental Verification", J. of the Brazilian Society of Mechanical Sciences and Engineering, Vol. 27, Apr. 2005.
- [13] Sullivan, J.W. and Crocker, M.J, "Analysis of Concentric-Tube Resonator Having Unpartitioned Cavities", J. of the Acoustical Society of America, Vol. 64, 1978, pp. 207-215.
- [14] S. Jeon, D. Kim, C. Hong, W. Jeong, " Acoustic Performance of Industrial Muffler with CAE Modeling and Simulation", International J. of Naval Architecture and Ocean Egeineering, Vol.6, Dec. 2014, pp. 935-946.

International Journal of GEOMATE, Aug., 2016, Vol. 11, Issue 24, pp. 2385-2390.

MS No. 5127j received on July 21, 2015 and reviewed under GEOMATE publication policies.

Copyright © 2016, Int. J. of GEOMATE. All rights reserved, including the making of copies unless permission is obtained from the copyright proprietors. Pertinent discussion including authors' closure, if any, will be published in April 2017 if the discussion is received by Oct. 2016.

Corresponding Author: Wei-Hong Tan
