

SETTLEMENT BEHAVIOUR OF PARIT NIPAH PEAT UNDER STATIC EMBANKMENT

*Adnan Zainorabidin¹, Mohamad Niizar Abdurahman², Azman Kassim³, Mohd Firdaus Md Dan Azlan⁴, Siti Nooraiin Razali⁵ and Engku Shahrulerizal Engku Ab Rahman⁶

^{1,4} Faculty of Civil and Environmental Engineering / Research Center for Soft Soil (RECESS), Universiti Tun Hussein Onn Malaysia, Malaysia;

² Public Works Department, Malaysia;

³ Faculty of Civil Engineering, Universiti Teknologi Malaysia, Malaysia;

⁵ Center for Diploma Studies, Universiti Tun Hussein Onn Malaysia, Malaysia;

⁶ Politeknik Kuching, Sarawak, Malaysia

*Corresponding Author, Received: 26 Nov. 2018, Revised: 02 Feb. 2019, Accepted: 16 Feb. 2019

ABSTRACT: Peat is considered as a very challenging soil when constructing any structure. It's known with high compressibility, high moisture content, low shear strength and long term settlement when subjected to load. These characteristics always posed constant problem for sustainable construction on peat. This study aims to investigate the settlement behaviour of peat fortified with concrete slab under embankment loading through full scale testing at Parit Nipah, Johor, Malaysia. The peat is categorized as hemic with moisture content greater than 500%. A concrete raft sized 3.6 m x 3.6 m with thickness of 150 mm was built on the site. The 3.6 m x 3.6 m slab was subjected to non-uniform loading. Results indicated that the installation of slab on peat able to reduce the settlement of peat under embankment loading. The study shows potential to mitigate or reduce long term post construction settlement on peaty ground.

Keywords - Peat, Concrete slab, Embankment, Settlement

1. INTRODUCTION

Geotechnical properties of foundation soil such as shear strength and compressibility of the soil are significant for construction of stable civil engineering structures [1]. Peat is defined as partially decaying vegetation remains amassed under saturated surroundings and in the absence of oxygen [2]. Peat in Malaysia is known as tropical woody peat and consists of semi-decomposed plant remains of tree stumps, roots, twigs, leaves and roots [2]. The colour of peat in Malaysia is generally dark reddish brown to black. Approximately 143,974 ha of land in Johor is covered with peat [3]. High compressibility of peat due to high void ratio, results in higher values of compression index, C_c and secondary compression, C_α compared to other types of soil [5]. According to Ibrahim [12], the void ratio, e_0 for peat reported up to 25 and compression index, C_c value for tropical peat can be up to 10 compared to clay which is only between 0.2 to 0.8. Zainorabidin [21] reports that the C_c value for West Malaysian peat, East Malaysian peat and Johor Hemic peat were 1.0 to 2.6, 0.5 to 2.5 and 0.9 to 1.5 respectively. Such attributes of peat pose undesirable challenges to the engineers in the field of construction [1].

According to Munro [15], peat can settle and consolidate in two ways under load. First is slow

settlement with a change in volume where gradual compression and consolidation allow time for the peat to respond to the applied load. This is the desired method to improve the bearing capacity and strength of peat. The second is rapid settlement without a change in volume where rapid spread and shear causes failure of the peat.

Peat has large initial settlement and short initial settlement period, usually days due to its very permeable nature [15]. During primary consolidation, pore water is being squeezed out from the peat under the load thus causing the peat fibers to compress and fill the void left due to the dissipation of pore water. Therefore, the magnitude of primary consolidation is dependent on the weight of embankment and the thickness of peat deposit. After this phase, the secondary compression with much slower settlement rate will take place. The secondary phase is generally accepted to be the result of peat mass slipping and re-organizing its fibers to form much denser medium. It has been stressed that peat should be loaded gradually enough for the peat to consolidate and gain strength [15].

Various construction methods and innovative approaches have been developed to mitigate settlement of structures on peat [1]-[2]. According to Ibrahim [12], the construction methods on peat can be categorized into two aspects – (1) construction by removal of peat and (2)

construction by peat left in place. Construction by peat left in place is carried out by modifying the ground using different techniques to increase the soil strength and thus making it sustainable to support the intended construction [12]. Five construction techniques under the peat left in place method are accelerating consolidation, ground improvement, stabilization, load modification and piling [12] & [15]. Table 1 lists the summary of construction techniques and methods used under the peat left in place approach.

Table 1 Summary of construction techniques under peat left in place approach [12]

Construction Technique	Method
Accelerating Consolidation	<ul style="list-style-type: none"> • Preloading • Stage construction • Vertical drains
Ground Improvement	<ul style="list-style-type: none"> • Stone column • Cement column • Soil column • Geopier • Surface reinforcement
Stabilization	<ul style="list-style-type: none"> • Mass stabilization
Load Modification	<ul style="list-style-type: none"> • Profile lowering • Pressure berms • Slope reduction • Lightweight fill • Offloading • Floating foundation
Piling	<ul style="list-style-type: none"> • End bearing piles • Friction piles • Settlement reducing piles • Tension piles • Laterally loaded piles • Piles in fills

The concrete raft foundation is categorized under load modification techniques. It is also considered as a floating foundation [12]. Munro [15] stated that, concrete rafts have been used successfully in Ireland and Scotland from the 1920's through to the 1950's. Concrete rafts can perform effectively by reducing the total and differential settlement of a foundation by decreasing the net applied load by excavation [16]. Table 2 lists the advantages of concrete raft construction. Concrete rafts are still in service over a deep blanket of bog deposits in Northern Scotland providing a stable load bearing platform for modern traffic [15].

Table 2 Advantages of concrete raft techniques [15]

Technique	Advantage
Concrete Raft	<ul style="list-style-type: none"> • Limited site disturbance. • Provides long term stiff foundation for the embankment. • Aids stability. • Reduce differential settlements and lateral stress on the peat land surface. • Minimizes need for embankment fill material.



Fig. 1 Concrete raft used as a floating housing road in the Netherlands [15]

2. MATERIAL AND EXPERIMENTAL METHOD

The study was carried out at Parit Nipah, Johor, Malaysia. The thickness of peat at the study location is about 4 m and the ground water table is found at less than 1m from the ground surface. Underlying this layer is silty clay. Peat samples collected from the site and tested in the laboratory to determine the index properties of Parit Nipah peat (PNpt). As shown in Table 3, the index properties test results of PNpt are within the range as reported by [6]-[11]. The PNpt is categorized as Hemic peat according to fiber content percentage and Von Post scale.

Table 3 Index properties of Parit Nipah peat

Parameter	Parit Nipah Peat	Range [6]-[11]
Moisture Content, %	635	236-784
Liquid Limit, %	252	220-417
Specific Gravity, G_s	1.34	1.27-1.56
Bulk Density, kN/m^3	10.45	7.95-11.5
Organic Content, %	95.5	78.77-95.44
Fiber Content, %	37.8	40.97-63.77
Compression Index, C_c	1.48	0.9-1.5
Von Post Scale	H6	H5-H6

2.1 Field Test and Monitoring

Figure 2 shows concrete raft built on site sized 3.6 m x 3.6 m x 0.15 m subjected to non-uniform load.



Fig. 2 Setting up of raft for non-uniform loading

Embankment construction was done using sand in stages as shown in Table 4. The final loading applied on the raft was 10 kPa [4], [14] & [18]. The sand was packed in heavy-duty plastic bags with fixed weight of 20 kg.

Table 4 Multi-stage loading for non-uniform embankment

Stage	Mass, kg	Stress, kPa
Concrete Slab	4665.6	3.53
1 st Layer Sand	2880.0	2.18
2 nd Layer Sand	2640.0	2.00
3 rd Layer Sand	2400.0	1.82
4 th Layer Sand	2160.0	1.64
5 th Layer Sand	1920.0	1.45
6 th Layer Sand	1212.0	0.92

2.2 Instrumentation

The vertical settlement (displacement) of soil was monitored using geodetic surveying method. TOPCON AT-B4 auto level equipment was used to measure the settlement value with accuracy up to 0.001 m. Special settlement gauge staffs which are light and can withstand any weather conditions were developed and used in this study. Nine settlement gauge staffs were installed on the concrete raft and eight settlement gauge staffs installed on the ground surrounding the raft. Figure 3 illustrates the layout of instrumentations installed on site. The reading of the settlement and pore water pressure after application of load monitored and recorded every two hours during daylight (from 8 am till 6 pm) every day. The next layer of embankment load only added to the previous layer when the settlement readings were stable for more than 24 hours. Stable reading is considered achieved when the settlement reading is constant

for at least 24 hours. This process repeated until the final layer of embankment load was completed.

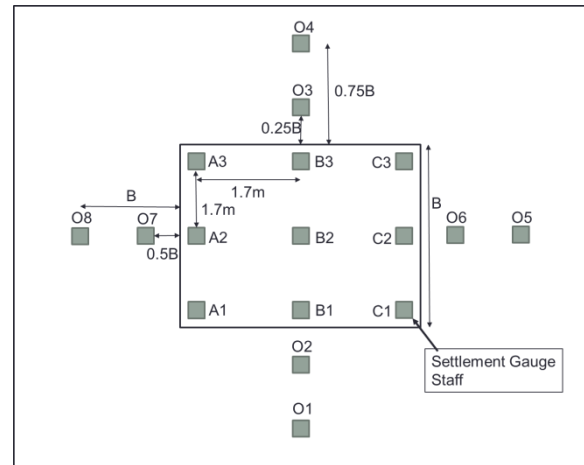

Fig. 3 Layout of instrumentation at site

3. RESULT ANALYSIS AND DISCUSSIONS

The average total settlement of the concrete raft measured for the duration of 75 days reaches 83.5 mm. As indicated in figure 4, the highest settlement rate was detected at point A3 measuring 104 mm, whereas the lowest settlement reading recorded at point C1 gauging 63 mm. After the end of embankment construction at 1468 hours, average settlement post construction recorder until 1786 hour was 9 mm. This is in line with the behavior of peat where it is susceptible to long term post construction settlement [19].

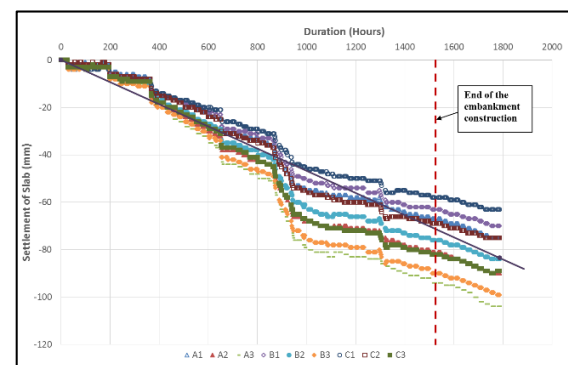

Fig. 4 Measured total settlements on the concrete raft

The settlement value of the concrete raft according to the load imposed is shown in Table 5. Due to the embankment loading, the raft is found to be tilting in the direction of point A3. Albeit tilting towards point A3, it is observed that the raft experience settlement at all points.

Table 5 Settlement value of concrete raft

Point	Load (kPa)					
	2.18	4.18	6.00	7.64	9.09	10.0
	Settlement (mm)					
A1	2	8	25	36	58	75
A2	3	10	32	45	72	90
A3	3	11	37	52	84	104
B1	3	8	23	34	55	70
B2	3	10	29	42	67	83
B3	4	11	34	49	80	97
C1	4	8	21	31	51	63
C2	2	8	25	37	61	75
C3	3	9	31	45	73	89

Figure 5 exhibits the settlement of raft under various loads imposed on it. Higher settlement values were recorded for load 6.00 kPa and 9.09 kPa compared to other load groups. The higher settlement reading is due to the duration that was taken for the reading to be stable under the concerning loads. The duration taken for the loads 6.00 kPa and 9.09 kPa were 12 days and 18 days respectively. Whilst for the other loads, the duration of the loading were between 7 to 9 days. Other factor that influence compressibility characteristics of peat is soil particle arrangements [20]. The crushing of peat fibers under 6.00 kPa and 9.09 kPa loads particularly might have caused increment in volume change of the soil due to the decrement of void ratio as a result of rearrangement of peat fibers and drainage of excess pore water pressure. Therefore longer duration taken for the settlement reading to be stable thus producing higher settlement values compared to other loads.

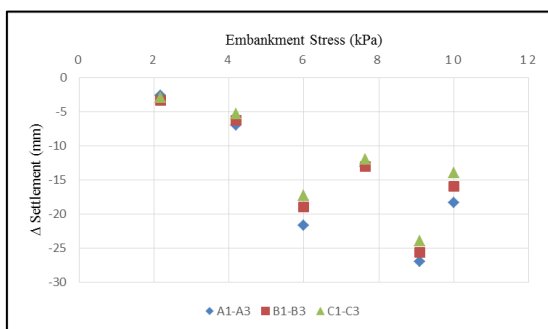

Fig. 5 Settlement of concrete raft under various embankment loadings

Figure 6 indicates that the soil surrounding the concrete raft experience deformation due to the embankment loading. Settlement gauge staffs placed at the distance of 0.25B and 0.5B have settled between 3 mm to 19 mm. Whereas reading of settlement gauge staffs located at 0.75B and 1B indicates occurrence of soil heaving between 1 mm

to 9 mm. The results also show that the increment of ground water table due to heavy rain causes the soil to swell and thus reducing the settlement or increasing the heaving. Nevertheless, the average settlement and heaving of the surrounding soil were 9 mm and 4 mm respectively. These values are still small if compared to the average settlement of raft, 83.5 mm.

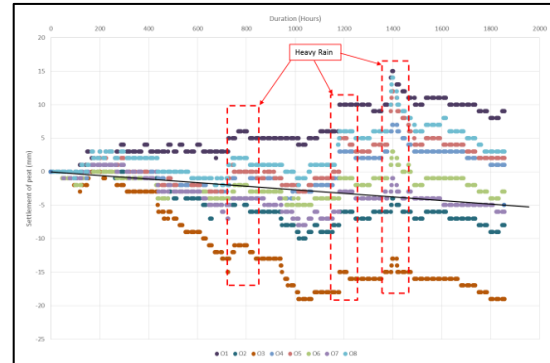

Fig. 6 Deformation of soil surrounding the concrete raft

4. CONCLUSION

Based on the review of the experimental results, the following concluding remarks were reached:

1. Stage loading method alleviates the immediate settlement of peat thus avoid unwarranted structural failure.
2. Usage of concrete raft foundation generates uniform settlement of peat under the embankment.
3. Fluctuation of ground water table effects the deformation of peat due to its shrinkage and swelling properties.
4. The settlement pattern of the concrete raft foundation is similar to that of punching shear.

5. ACKNOWLEDGEMENTS

The technical support provided by RECESS laboratory is duly acknowledged. Financial support for this study was provided by Research Grant TIER 1 Phase 1/2017, Office for Research, Innovation, Commercialization and Consultancy Management (ORICC), Universiti Tun Hussein Onn Malaysia. Scholarship funding by Jabatan Kerja Raya Malaysia is also very much appreciated.

6. REFERENCES

- [1] Wijeyesekera D. C., Numbikannu L., Ismail T. N. H. T., and Bakar I., Mitigating Settlement of Structures Founded on Peat. Soft Soil Engineering Conference, 2015.
- [2] Zainorabidin A., Static and Dynamic Characteristics of Peat with Macro and Micro Structure Perspective, University of East London, 2010, Ph.D Thesis.
- [3] Wetlands International, A Quick Scan of Peatlands in Malaysia, Wetlands International Malaysia, 2010.
- [4] Construction Research Institute of Malaysia (CREAM), Guideline for Construction on Peat and Organic Soils in Malaysia, 2015.
- [5] Sa'don N. M., Abdul Karim A. R., Ahamad Z., and Mariappan A., Sarawak Hemic Peat Consolidation Settlement and Shear Strength Behaviour, 15th International Peat Congress, 2016.
- [6] Zainorabidin A., and Mohamad H. M., Engineering Properties of Integrated Tropical Peat Soil in Malaysia, Electronic Journal of Geotechnical Engineering, Vol. 22, Bund. 02, 2017, pp. 457-466.
- [7] Zainorabidin A., Saedon N., and Mohd Seth N. F., An Investigation of Soil Volume Changes at Four Dimensional Points of Peat Soil in Parit Nipah and Pontian, International Integrated Engineering Summit, 2014.
- [8] Zainorabidin A., Zolkefle S. N. A., Lim A. J. M. S., Mohamad H. M., and Mohd Razali S. N., Comparison Study of the Dynamic Loading Characteristics between Peat and Sand on its Physical Properties, Applied Mechanics and Materials, 2015, pp. 1460-1465.
- [9] Zainorabidin A., and Bakar I., Engineering Properties of In-Situ and Modified Hemic Peat Soil in Western Johor, In Proceedings of 2nd International Conference on Advances in Soft Soil Engineering and Technology, 2003, pp. 173-182.
- [10] Zolkefle S. N. A., Zainorabidin A., Harun S. F., and Mohamad H. M., Influence of Damping Ratio and Dynamic Shear Modulus for Different Locations of Peat, International Journal of Integrated Engineering, Special Issue, Vol. 10, No. 9, 2018, pp. 48-52.
- [11] Razali S. N. M., Zainorabidin A., Bakar I., and Mohamad H. M., Strength Changes in Peat-Polymer Stabilization Process, International Journal of Integrated Engineering, Special Issue, Vol. 10, No. 9, 2018, pp. 37-42.
- [12] Ibrahim A., Huat B. B. K., Asadi A., and Nahazanan H., Foundation and Embankment Construction in Peat: An Overview, Electronic Journal of Geotechnical Engineering, Vol. 19, Bund. Z₂, 2014, pp. 10079-10094.
- [13] Waruwu A., Hardiyatmo H. C., and Rifa'i A., Compressive Behavior of Bagansiapiapi-Riau Peat in Indonesia, Electronic Journal of Geotechnical Engineering, Vol. 21, Bund. 16, 2016, pp. 5217-5227.
- [14] Sasaki Y., Characterisation of Expanded Polymer Resin and Expansive Soil Composites, University of Newcastle, 2008, Ph.D Thesis.
- [15] Munro R., Dealing with Bearing Capacity Problems on Low Volume Roads Constructed on Peat, The Highland Council, Transport, Environmental & Community Service, HQ, Glenurquhart Road, Inverness IV3 5NX Scotland, 2004.
- [16] Mohsenian S., Eslami A., and Kasaei A., Geotechnical Aspects for Design and Performance of Floating Foundations, ASCE Geo-Frontiers, 2011, pp. 56-65.
- [17] Suro S. M., Bakar I., and Sulaeman A., Pile Space Optimization of Short Piled Raft Foundation System for Obtaining Minimum Settlement on Peat, Material Science and Engineering, 2016, pp. 1-7.
- [18] Tuan Ismail T. N. H., A Critical Performance Study of Innovative Lightweight Fill to Mitigate Settlement of Embankment Constructed on Peat Soil, Universiti Tun Hussein Onn Malaysia, 2017, Ph.D Thesis.
- [19] Mohd Razali S. N., Bakar I., and Zainorabidin A., Behavior of Peat Soil in Instrumented Physical Model Studies, Procedia Engineering 53, 2013, pp. 145-155.
- [20] Kazemian S., Huat B.K.K., Prasad A., and Barghchi M., A State of Art Review of Peat: Geotechnical Engineering Perspective, International Journal of the Physical Sciences Vol. 6(8), 2011, pp. 1974-1981.
- [21] Zainorabidin A., Wijeyesekera D.C. and Masirin M.I., Comparative Study of British and Malaysian Peat Soils Pertaining to Geotechnical Characteristics, In Proceedings of SLGS2007 1st International Conference on Soil & Rock Engineering, 2007.