

## SEISMIC ANALYSIS OF DAM-RELEVANT STRUCTURES IN NORTHERN THAILAND

\*Bhuddarak Charatpangoon<sup>1</sup>, Chayanon Hansapinyo<sup>1</sup>, and Junji Kiyono<sup>2</sup>

<sup>1</sup>Center of Excellence in Natural Disaster Management, Faculty of Engineering, Chiang Mai University, Thailand; <sup>2</sup>Graduate School of Engineering, Kyoto University, Japan.

\*Corresponding Author, Received: 13 Sep. 2019, Revised: 04 Oct. 2019, Accepted: 27 Oct. 2019

**ABSTRACT:** The damages and losses caused by dam failure are significant. Currently, the seismic safety of dams is well established. However, a study concerning the seismic safety of dam-relevant structures is necessary. Occasionally, dams may withstand an earthquake; however, they are often unable to operate after the quake due to malfunctioning dam-relevant structures. Furthermore, the collapse of such structures could lead to a dam failure or cause considerable losses to the society downstream as well. Therefore, the seismic safety of dam-relevant structures cannot be neglected, and such safety precautions must be conducted properly. The main goal of this research is to evaluate the seismic safety of a dam spillway in Northern Thailand and to ensure that it can operate normally after an expected large earthquake. First, a representative dam-relevant structure is selected based on the availability of data and its importance. Afterward, the performance goal of a representative structure will be established upon its importance, expected performance, and ground motion level. For example, all structural components must be intact, and the uncontrollable release of reservoir water must not take place during and after the maximum considered earthquake (MCE). The seismic analysis of a representative structure is then performed using a numerical simulation. Finally, based on the results, suggestions are made regarding the seismic safety of the representative structure.

*Keywords: Dynamic, Seismic safety, Dam relevant structure, Earthquake*

### 1. INTRODUCTION

Earthquakes are natural disasters causing massive devastation to cities. Efforts have been made to mitigate or minimize the risk. Many researchers [1, 2] proposed methods for building seismic damage assessment. However, not only buildings, the damages and losses caused by dam failure are also significant, and such failures have the potential to destroy entire cities. Seven earth dams were damaged by 2011 Off the Pacific Coast of Tohoku Earthquake [3]. Dams are essential for the survival of a community, as they provide water and power. Currently, the seismic safety of dams is well established. However, studies concerning the seismic safety of dam-relevant structures, such as control centers, gates, and spillways, are still necessary.

In some cases, dams may withstand the initial earthquake; however, they may be unable to operate after the quake due to malfunctioning dam-relevant structures. Furthermore, the collapse of such structures could lead to a dam failure or cause significant losses to the society downstream as well. For example, the damage or collapse of a spillway or control center may cause a dam to stop operating due to safety issues or may even trigger the uncontrollable release of the reservoir water. Therefore, the importance of this issue cannot be neglected, and studying it must be conducted in a

proper way.

Recently, some researchers [4, 5] have revised the seismic design code for such structures. For example, Wieland and ICOLD mentioned that the seismic design of such structures must ensure that the structures, their components, and their equipment must be fully operable during and after an earthquake.

In 1996, the Applied Technology Council published the ATC-40 Seismic Evaluation and Retrofit of Concrete Buildings [6], which introduced performance-based seismic design and the detailed procedure for performing the seismic analysis and safety evaluation of buildings. The performance-based design method provided information on the building behavior under the selected level of shaking based on the potential hazard at the site.

In 1997, the NEHRP Guidelines for the Seismic Rehabilitation of Buildings (FEMA 273) [7] established various performance levels: Operational, Immediate Occupancy, Life Safety, and Collapse Prevention. Furthermore, the guidelines defined ground motion for extremely rare event earthquakes (2,475-year return period) or for the Maximum Considered Earthquake Ground Motions (MCE) and Design Basis Event earthquakes (DBE; 475-year return period), and DBE was 2/3 of the MCE. Generally, the code aimed to prevent buildings from collapse under

MCE. Then, the ground motion level and its corresponding performance objective must be selected; for example, Collapse Prevention could be paired with the MCE.

In general, most codes and standards focus on ordinary buildings. Although some codes may provide additional design concepts to evaluate the seismic safety of other important structures, evaluations of dam-relevant structures are still seldom. In 2008, Ariga [8] proposed a method to evaluate the seismic safety of spillways accurately by considering all structural components through using numerical simulation with 3D dynamic analyses. Similarly, Adya [9] studied a modeling and numerical simulation for the dynamic analysis of gravity dam spillways. Recommendations regarding the modeling of dam spillways and other factors related to the dynamic analysis of dam spillways were provided.

In Thailand, the seismic design criteria in the National Standard DPT 1302: Seismic Resistant Design of Buildings and Structures (by Department of Public Works and Town & Country Planning, Ministry of Interior, Thailand) [10, 11] provided MCE and DBE; however, the damage level may only prevent the building from collapse. In fact, the performance level of dam-relevant structures must be at the operational level.

Furthermore, there are active faults capable of generating a moderate to a large earthquake in Northern Thailand. On May 5, 2014, the 6.1M<sub>w</sub> Mae Lao earthquake trembled north Thailand and Myanmar. It was the strongest earthquake ever recorded in Thailand, according to the National Disaster Warning Center [12, 13]. The earthquake resulted in one death and damaged numerous buildings, roads, and temples. Accordingly, researches [14] identified critical buildings and prioritize their repairing requirements using fuzzy logic. It was found that the buildings having more important and high indirect impacts on the community, such as hospital buildings and other infrastructures were considered with a higher priority for seismic safety.

Therefore, to eliminate these limitations, this research aims to propose a proper systematic method to evaluate the seismic safety of dam-relevant structures and to verify that such structures can be operated normally after an expected large earthquake.

## 2. SITE AND GROUND MOTIONS

The selected site of this study is Kiew Kho Ma Dam, which is a zoned earth dam located in the Chae Hom district, Lampang province, Northern Thailand (Lat 18-48'-24" N, Long 99-38'-48" E). The dam is established on the Wang River, a tributary of Chao Phraya River, 61 km northeast of

Lampang. The dam is located 90 km away from the 2014 Mae Loa earthquake epicenter (Fig.1). Construction on the dam began in 2005, and it was completed in 2010. The dam was built not only to prevent floods but also to provide water for irrigation, human consumption, and industrial use in Lampang. The main dam is 43.5 m tall and 500 m long, and it is an earth-zoned type with a crest width of 8 m. the storage capacity is 170 Mm<sup>3</sup>. The Kiew Kho Ma Dam consists of three dam-relevant structures: the spillway, the generator, and the river outlet [15]. In this study, according to the availability of data and its importance to the dam, the dam spillway was selected as a representative dam-relevant structure.

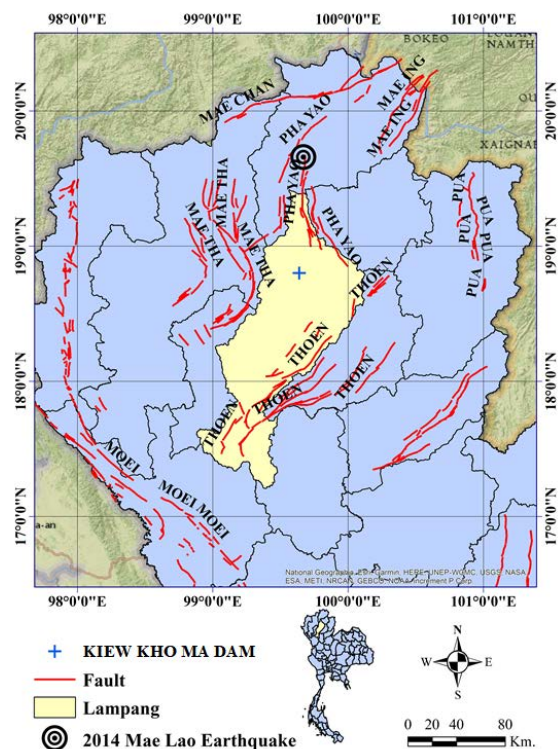

Fig. 1 Kiew Kho Ma Dam and the 2014 Mae Loa earthquake



Fig. 2 Kiew Kho Ma Dam and its spillway [16]

### 2.1 The Kiew Kho Ma Dam spillway

The Kiew Kho Ma Dam spillway is located on the right of the main dam (from upstream), as shown in Fig. 2. The spillway is a reinforced concrete structure with three 12.5 x 7.00 m radial gates (Fig. 3). The overall length of the spillway is 800 m, and the drainage channel width is 42.5 m. The maximum reservoir level is 352.90 m (MSL), with a spillway capacity of 1,209 m<sup>3</sup>/s (1,000-year return period) [15].



Fig. 3 The Kiew Kho Ma Dam spillway

### 2.2 Ground motions

The maximum considered earthquake (MCE  $\approx$  2,475-year return period) was selected for use. At the MCE level, all structural components must be intact, and the uncontrollable release of reservoir water must not occur. Due to the lack of ground motion records in Thailand, three earthquake records were carefully selected to represent three possible earthquake scenarios. These records were chosen by considering the earthquake characteristics at the site, such as site condition, source-site distance, magnitude, and fault mechanism. There are several active faults located close to the Kiew Kho Ma Dam. The closest active fault is the Central Phayao fault, which is a normal fault located 20 km away from the site, while the Pua fault is an active normal fault located approximately 100 km from the dam. The selected ground motions are the 2001 Washington earthquake  $M_w$  6.8, the 2001 El Salvador  $M_w$  7.6 [17], and the 1997 Northwest China-03 earthquake  $M_w$  6.1 [18]. Table 1 presents information about the selected records. To introduce the ground motions at the site, these records were modified to match the target response spectrum at the dam site. The target response spectrum (MCE, soil type D was assumed) was generated following the National Standard DPT 1302: Seismic Resistant Design of Buildings and Structures [10]. The peak ground accelerations of the matched accelerograms

were 3.37, 3.15, and 4.10 m/s<sup>2</sup> for EQ1, EQ2, and EQ3, respectively. The matched ground motions, along with the matched response spectrum, are shown in Figs. 4-6 for EQ1, EQ2, and EQ3, respectively.

Table 1 Input motions

Data	Input Motions		
	EQ1	EQ2	EQ3
Event	Washington	El Salvador	Northwest China-03
Station	Olympia	Relaciones Exteriores	Jiashi
Year	2001	2001	1997
Magnitude	6.8 ( $M_w$ )	7.6 ( $M_w$ )	6.1 ( $M_w$ )
PGA	0.250g	0.304g	0.301g
Epicentral Distance	18.34 km	95.63 km	9.98 km
Fault Mechanism	Normal	Normal	Normal

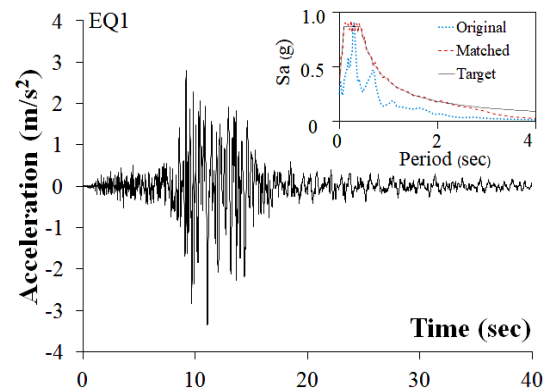

Fig. 4 EQ1

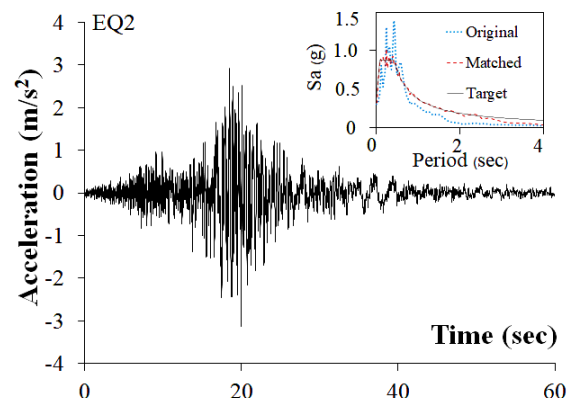

Fig. 5 EQ2

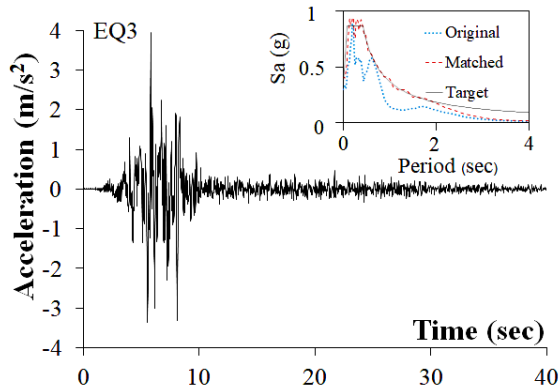

Fig. 6 EQ3

### 3. NUMERICAL MODEL

#### 3.1 The Kiew Kho Ma Dam spillway model

The commercial finite element package LS DYNA [19] was used in the 3D finite element model adopting a 3D solid element coded ELEMENT\_SOLID for concrete elements and a beam element coded ELEMENT\_BEAM for reinforcing steel. The model was divided into two main parts: the gantry frame and the spillway. The gantry frame was analyzed using the non-linear behavior of both the concrete (MAT\_CONCRETE\_DAMAGE\_REL3, MCDR3) [20], as shown in Fig. 7, and the reinforcing steel (MAT\_PIECEWISE\_LINEAR\_PLASTICITY) by considering the perfect bonding between them. In MCDR3 model, the non-linear behavior of concrete was reproduced through the failure surface (Fig. 7) by giving simple concrete parameters such as density, compressive strength, and Poisson ratio. For the spillway, linear behavior (MAT\_ELASTIC) was assumed.

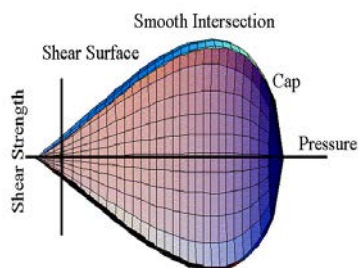

Fig. 7 Failure surface of

MAT\_CONCRETE\_DAMAGE\_REL3 [14]

The model is comprised of 210,487 elements with 227,392 nodes (Fig. 8). The model was fixed in all directions at the base. In this study, the effect

of reservoir water-soil-structure interaction was neglected. The analysis started by introducing the gravity load to the model. The explicit finite element method was used for the dynamic analyses. Then, three cases of the y-directional input motions were applied at the model's base (longitudinal directions). Fig. 9 shows the dimensions of the Kiew Kho Ma Dam spillway and its components. Fig. 9 illustrates the typical cross-section of the gantry frame's columns and deck.

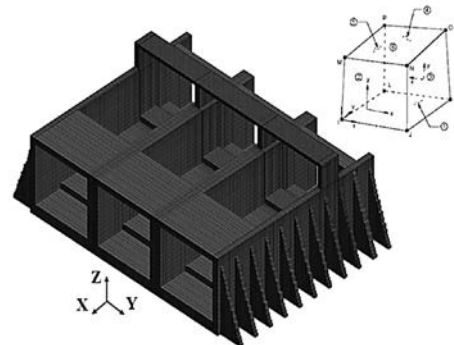
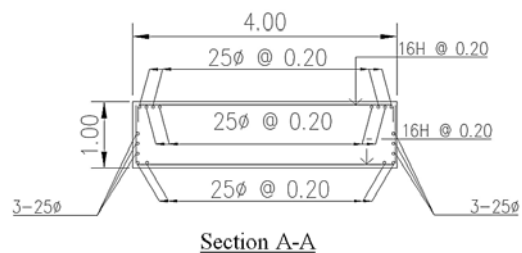
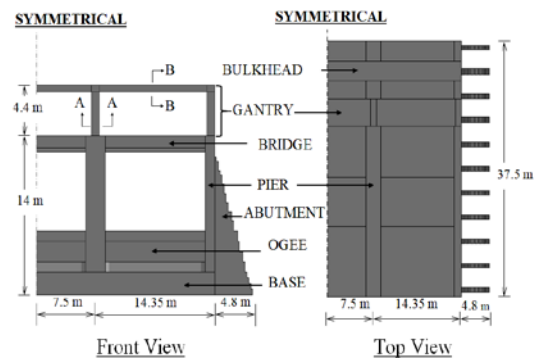
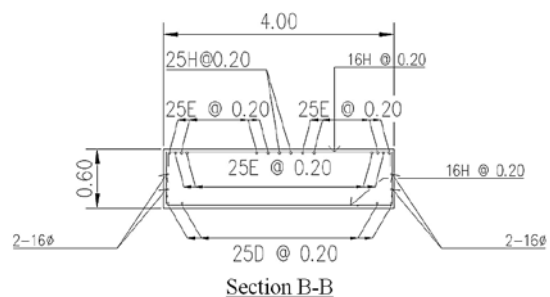

Fig. 8 The Kiew Kho Ma Dam spillway model



Section A-A



Section B-B

Fig. 9 The Kiew Kho Ma Dam spillway's typical sections

### 3.2 Material properties

The spillway is a reinforced concrete structure. The material properties of reinforcing steel and concrete were obtained from the design drawing and the design specification. Table 2 shows the parameters used in this study, such as modulus of elasticity ( $E$ ), Poisson Ratio ( $\nu$ ), density ( $\rho$ ), compressive strength ( $f'_c$ ), tensile strength ( $f_t$ ).

Table 2 Material properties

Component	$E$ (GPa)	$\nu$	$\rho$ (kg/m <sup>3</sup> )	$f'_c$ (MPa)	$f_t$ (MPa)
Gantry frame	-	0.19	2400	32.0	3.2
Longitudinal bar	204	0.30	7830	-	300
Stirrup	204	0.30	7830	-	300
Spillway	26.5	0.19	2400	32.0	3.2

### 4. NATURAL FREQUENCY

This part consists of ambient vibration measurement and numerical simulation. The ambient vibration test results were used to verify the finite element model.

A microtremor test was performed to acquire the linear vibration characteristics of the Kiew Kho Ma Dam spillway. This measurement was performed using velocity sensors. The equipment was composed of four velocity transducers (three directional), with x, y, and z measurements for each sensor. The velocity transducers were placed at the top of the Kiew Kho Ma Dam spillway (points A-D) to obtain the translational vibration mode shape, as shown in Fig. 10. Then, the three directional velocity records in the time domain were changed into the frequency domain by the fast Fourier transformation technique. Hence, the natural frequency can be determined by observing the frequency at the peak value of the Fourier amplitude. The ambient vibration measurements showed that the fundamental mode of this structure is a translation in the y-direction (longitudinal direction), and the natural frequency is approximately 8.25 Hz (Fig. 10), which is within the range of a stiff building characteristic. The translation in the x-direction (transverse direction) is approximately 21.25 Hz.

From the modal analysis, the fundamental mode of this structure is a translation in the y-

direction (Fig. 11). The natural frequency is approximately 7.76 Hz, with the high movement only in the top part (gantry frame). The second mode is the torsional mode with a frequency of approximately 8.96 Hz. The translation in the x-direction is approximately 20.70 Hz due to the large stiffness in the x-direction.

Table 3 shows that the measurement results and simulation results are in good agreement. The differences between both results were only 5.9% in the y-direction and 2.57% in the x-direction, respectively. Hence, the finite element model is a close approximate to the Kiew Kho Ma Dam spillway.

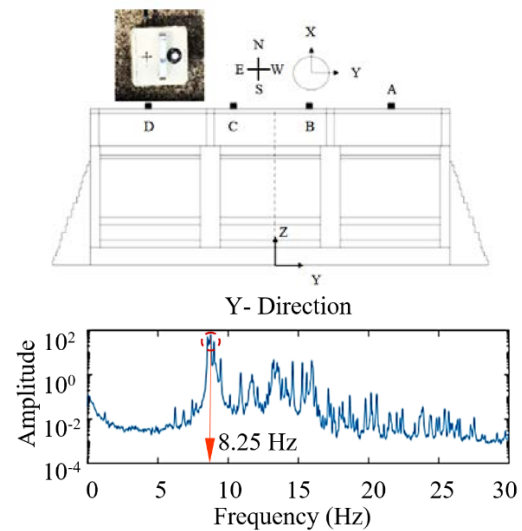

Fig. 10 Ambient vibration measurement

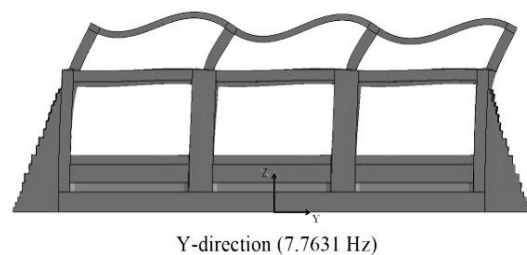

Fig. 11 Fundamental mode (Modal analysis)

Table 3 Material properties

Mode Shape	Frequencies (Hz)		Error %
	Ambient vibration	Modal Analysis	
Y-translation	8.25	7.76	5.90
X-translation	21.25	20.70	2.57
Torsional	N/A	8.96	-

### 5. STRUCTURAL RESPONSES

The structural responses of the Kiew Kho Ma Dam spillway, as determined using finite element analyses, were expressed through the acceleration, deformation, stress, and plastic strain. Fig. 12 provides the observation points that were used to obtain the model's structural responses.

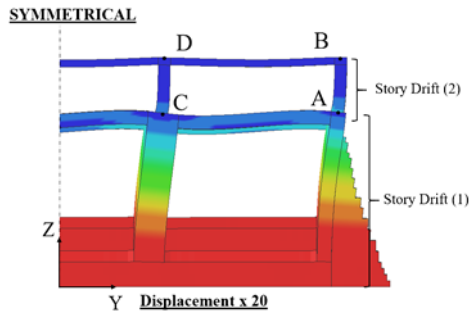

Fig. 12 Observation points and story drift

By considering the acceleration responses, the maximum acceleration  $A_y$  is  $3.88 \text{ m/s}^2$  using EQ1. The maximum acceleration can be observed at point A (the top of the pier), while point B (the top of the gantry frame) experienced a slightly lower acceleration. At point B, the maximum acceleration is  $3.5 \text{ m/s}^2$ . The maximum amplification ratios ( $A_{y,MAX}/PGA$ ) are approximately 1.16 for point A and 1.04 for point B. The de-amplification of the gantry frame's acceleration can be observed in all cases. This de-amplification was due to the plastic deformation and the energy dissipation of the material model applied in the gantry frame.

Fig. 13 illustrated the deformed mesh at 15.0 s and its corresponding longitudinal displacement time-history plots for points A and B when subjected to EQ2. Tables 4-6 provide the responses, such as displacement, story drift, acceleration, and acceleration amplification ratio, of the analysis model when subjected to EQ1, EQ2, and EQ3, respectively.

The maximum longitudinal displacement  $U_y$  is 7.95 cm at point A, while the maximum up-downstream displacement  $U_x$  was found to be insignificantly small. The story drifts along the y-direction showed that the piers of the spillway on both ends were displaced more than those at the center. The maximum story drift of the gantry frame (2) is approximately 4.0 cm, while the maximum story drift of the spillway pier (1) is approximately 7.95 cm. According to the Thailand National Standard DPT 1302 [10], the maximum story drift must not exceed  $0.01 H$  ( $H$  is story height). Therefore, the allowable story drift is 4.4 cm for the gantry frame (2) and 14 cm for the spillway pier. Hence, the displacement responses

from all cases were lower than the allowable story drift.

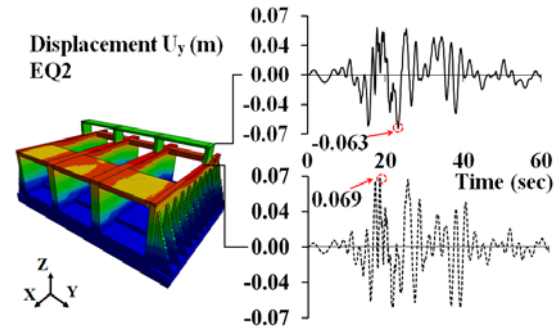

Fig. 13 Displacement,  $U_y$  subjected to EQ2

Table 4 Results obtained using EQ1

Node	Height (m)	$U_y$ (cm)	$A_y$ ( $\text{m/s}^2$ )	Story Drift (cm)	$\frac{A_{y,MAX}}{PGA}$
A	14	7.95	3.88	7.95(1)	1.16
B	18.4	7.30	3.50	3.95(2)	1.04
C	14	7.84	3.66	7.84(1)	1.09
D	18.4	7.19	3.04	3.30(2)	0.91

Table 5 Results obtained using EQ2

Node	Height (m)	$U_y$ (cm)	$A_y$ ( $\text{m/s}^2$ )	Story Drift (cm)	$\frac{A_{y,MAX}}{PGA}$
A	14	6.91	2.92	6.91(1)	0.93
B	18.4	-6.32	2.77	4.00(2)	0.88
C	14	7.05	2.93	7.05(1)	0.94
D	18.4	7.05	2.78	3.59(2)	0.88

Table 6 Results obtained using EQ3

Node	Height (m)	$U_y$ (cm)	$A_y$ ( $\text{m/s}^2$ )	Story Drift (cm)	$\frac{A_{y,MAX}}{PGA}$
A	14	-7.66	3.35	7.66(1)	0.85
B	18.4	6.03	3.26	3.15(2)	0.83
C	14	-7.41	3.51	7.41(1)	0.89
D	18.4	5.97	3.25	2.82(2)	0.82

Figs. 14 - 15 show the maximum and minimum principal stresses of the gantry frame at the time when the peak values were reached. The results showed that the high value of the maximum principal stress (Fig. 14) was observed on the bottom of the gantry deck at its mid-span, column-deck joint, as well as the lower portion of the gantry column. The maximum value of the maximum principal stress was about 6.95 MPa. However, the overall maximum principal stress was extremely small and insignificant. For the

minimum principal stress, the lowest minimum principal stress was formed at the lower portion of the gantry column. The lowest minimum principal stress was 62.8 MPa. Accordingly, the plastic deformation was expected to occur around that particular location.

Fig. 16 illustrated the axial stress in the rebar. The results yielded that the highest value of the axial stress was formed at the lower portion of the column's rebar. The maximum axial stress was approximately 400 MPa. Hence, the plastic deformation of the rebar was expected to occur.

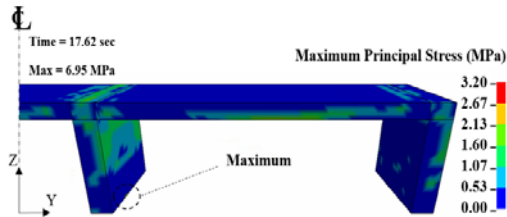

Fig. 14 Maximum principal stress (EQ2)

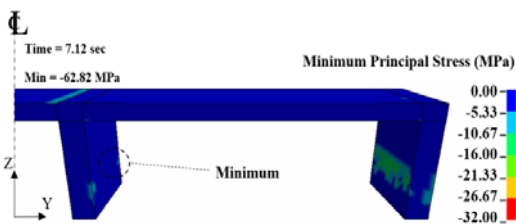

Fig. 15 Minimum principal stress (EQ2)

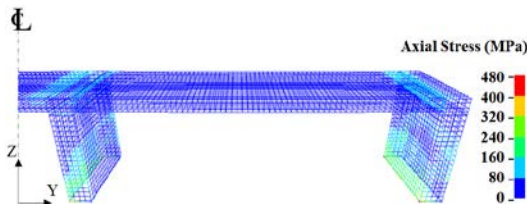

Fig. 16 Axial stress in rebar (EQ2)



Fig. 17 Effective plastic strain in concrete (EQ2)

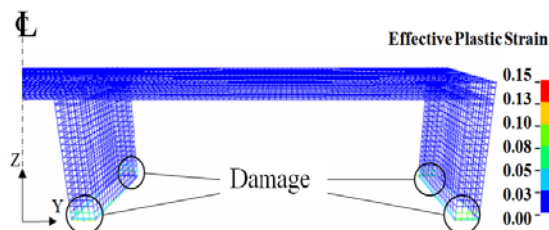

Fig. 18 Effective plastic strain in rebar (EQ2)

Structural damage can be observed via the effective plastic strain. This effective plastic strain can be captured only when using non-linear material models. Therefore, only the damage to the gantry frame can be assessed. For the concrete, the damage can be found mostly around the lower part of the gantry columns (Fig. 17). The results also showed that the gantry columns at both ends were subjected to less damage than those at the center. Similar results were obtained for the reinforcing steel, as the damage can be observed mostly at the lower portion of the gantry columns (Fig. 18).

## 6. CONCLUSIONS

This study was conducted to evaluate the seismic safety of the Kiew Kho Ma Dam spillway. When considering the importance of a dam spillway, all structural components must be intact, and the uncontrollable release of reservoir water must not take place when subjected to MCE. The structure's seismic responses show that only minor damage to the gantry frame could be observed. For both concrete and reinforcing steel, the damage was found mostly around the lower part of the gantry columns. Furthermore, the maximum story drift of the gantry frame was lower than that of the allowable story drift provided in the Thailand National Standard DPT 1302 [10].

Therefore, it can be summarized that the Kiew Kho Ma Dam spillway is safe against MCE, as it satisfies the expected seismic performance level.

## 7. ACKNOWLEDGMENTS

This work was supported by the Thailand Research Fund and Office of Higher Education Commission (MRG6080109).

The authors like to express our gratitude to Associate Professor. Dr. Nakhorn Poovarodom, Faculty of Engineering, Thammasat University for assistance with ambient vibration measurements, and Associate Professor. Dr. Suttisak Soralump, Faculty of Engineering, Kasetsart University, for his supports and comments during this research.

## 8. REFERENCES

- [1] Ketsap A., Hansapinyo C., Kronprasert N. and Limkatanyu S., Uncertainty and fuzzy decisions in earthquake risk evaluation of buildings, *Engineering Journal*, Vol. 23, Issue 5, 2019, pp. 89-105.
- [2] Saicheur K. and Hansapinyo C., Seismic loss estimation and reduction after structural rehabilitation in Chiang Rai City, *Walailak Journal of Science and Technology*, vol. 14, no. 6, 2017, pp.485-499.

- [3] Charatpangoon B., Kiyono J., Furukawa A. and Hansapinyo C., Dynamic analysis of earth dam damaged by the 2011 Off the Pacific Coast of Tohoku earthquake, *Soil Dynamics and Earthquake Engineering*, Vol. 64, 2014, pp.50-62.
- [4] ICOLD., Seismic design and evaluation of structures appurtenant to dams. Commission Internationale des Grands Barrages. Bulletin 123, 2002.
- [5] Wieland M., Seismic Hazard and Seismic Design and Safety Aspects of Large Dam Projects. *Geological and Earthquake Engineering* 34, 2012.
- [6] Applied Technology Council., Seismic Evaluation and Retrofit of Concrete Buildings (ATC 40), Seismic safety commission state of California. Inc., 1996.
- [7] Federal Emergency Management., NEHRP Guidelines for the Seismic Rehabilitation of Buildings (FEMA 273), 1997.
- [8] Ariga Y., Study on earthquake damage mechanism and measures of spillway composed of concrete piers with different shapes and dynamic response properties, in Proc. 14th World Conference on Earthquake Engineering, 2008.
- [9] Adya A., FE modeling and numerical simulation for dynamic analysis of gravity dam spillways, in Proc. 14th World Conference on Earthquake Engineering, 2008.
- [10] Department of Public Works and Town & Country Planning, Ministry of Interior, Thailand., Seismic design criteria in National Standard DPT 1302: Seismic Resistant Design of Buildings and Structures, 2009.
- [11] Ornthammarath T., Warnitchai P., Worakanchana K., Zaman S., Sigbjornsson R. and Lai C., Probabilistic seismic hazard assessment for Thailand, *Bull Earthquake Eng*, Vol. 9, Issue 2, 2010, pp. 367-394.
- [12] U.S. Geological Survey USGS., M 6.1 – 13 km NNW of Phan, Thailand, accessed August 2, 2019, at URL <https://earthquake.usgs.gov/earthquakes/eventpage/usb000qack/executive>.
- [13] Earthquake-Report.com., Very strong deadly earthquake close to Chiang Rai, Thailand - At least 1 dead and 32 injuries + huge number of aftershocks, accessed August 23, 2017, at URL <https://earthquake-report.com/2014/05/05/strong-earthquake-thailand-on-may-5-2014/>.
- [14] Saicheur K. and Hansapinyo C., Structural repair prioritization of buildings damaged after earthquake using fuzzy logic model, *Journal of Disaster Research*, vol. 11, no. 3, 2016, pp. 559-565.
- [15] Electricity Generating Authority of Thailand EGAT., Kiew Kho Ma Dam, accessed August 23, 2017, at URL <https://www.egat.co.th/en/information/power-plants-and-dams?view=article&id=481>.
- [16] Google earth (January 22, 2017). 18°48'34.85"N, 99°38'41.80"E, Eye alt 1.96 km. DigitalGlobe 2018. <http://www.earth.google.com> [December 26, 2018].
- [17] CESMD Strong-Motion Data Set., accessed August 23, 2017, at URL <https://www.strongmotioncenter.org>.
- [18] Pacific Earthquake Engineering Research Center (PEER) ground motion database., accessed August 23, 2017, at URL <https://peer.berkeley.edu/peer-strong-ground-motion-databases>.
- [19] Hallquist J. O., LS-DYNA keyword user's manual, Livermore Software Technology Corporation (LSTC). version 971, Vol. 1, 2010.
- [20] Federal Highway Administration., Users manual for LS\_DYNA concrete material model 159. Publication, No. FHWA-HRT-05-062, 2007.

---

Copyright © Int. J. of GEOMATE. All rights reserved, including the making of copies unless permission is obtained from the copyright proprietors.

---